

# **NAMFOG: Namibian Application of Fog-Collecting Systems**

## **Phase I: Evaluation of Fog Water Harvesting**

*by: Joh Henschel, Vilho Mtuleni, Nina Gruntkowski,  
Mary Seely & S. Elias Shanyengana*

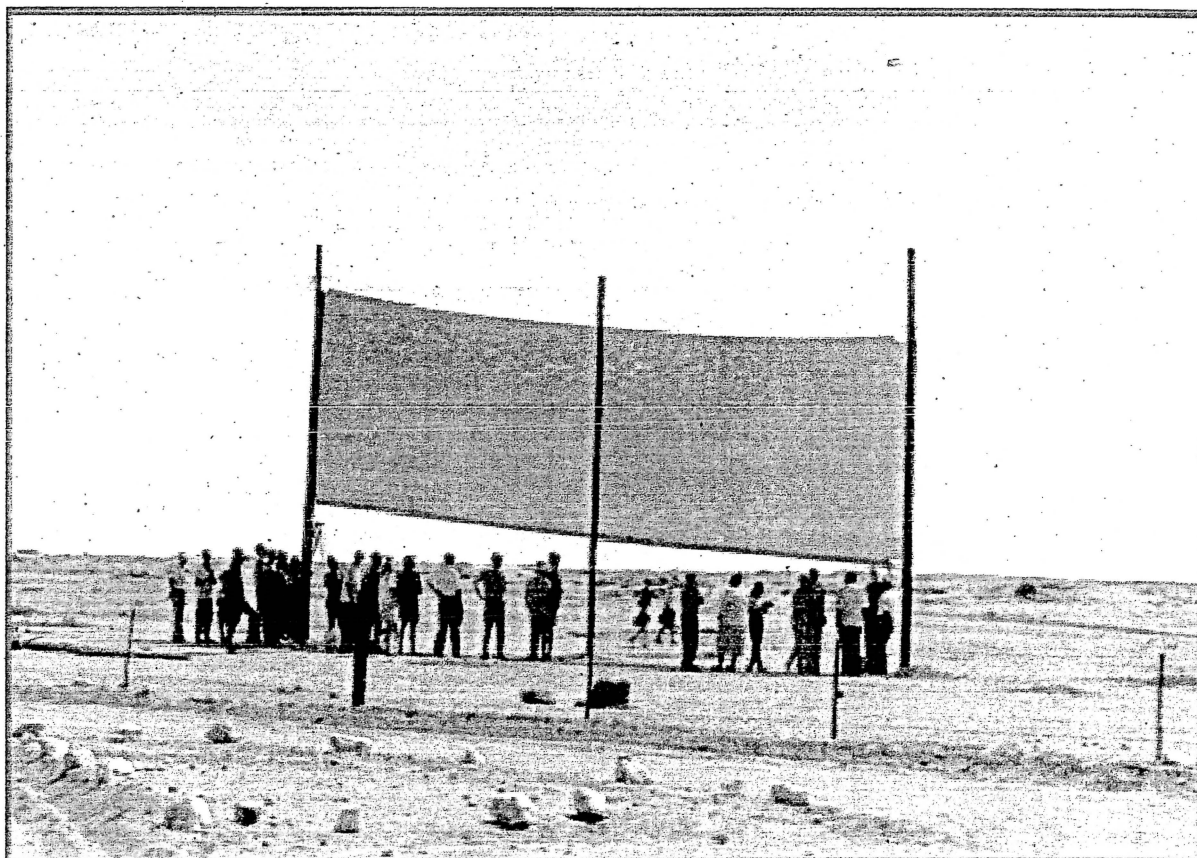

**OCCASIONAL PAPER NO 8**

**ISBN 99916-43-31-1**

May 1998

© Desert Research Foundation of Namibia (DRFN)

Gobabeb P.O.Box 953 Walvis Bay Namibia

**SPONSORED BY:**

**International Development Research Centre, Canada (IDRC)**

**Environmental Capacity Enhancement Project, Guelph University, Canada (ECEP)**

**Publication costs were funded by ECEP**

# NAMFOG PROJECT

## NAMIBIAN APPLICATION OF FOG-COLLECTING SYSTEMS

### PHASE I: EVALUATION OF FOG-WATER HARVESTING

#### Summary

Fog transports water into the hyperarid Namib Desert. Working together, the DRFN and the resident Topnaar community evaluated the potential of this water being collected for domestic purposes following a model case in Chile. The evaluation entailed studying climatological, temporal and spatial parameters of Namib fog, determining the water needs and ensuring participation and awareness by potential consumers of fog water. This report recommends whether, how and where fog water can be collected to help alleviate the water shortage along the lower Kuiseb valley in the Namib Desert.

The twelve objectives of phase 1 of the project concern the quantity and quality of fog water, the collecting equipment, the water needs, information transfer, the identification of socioeconomic and environmental consequences, the design of a fog water supply scheme, the production of a report and publications, dissemination of information and plans of phases 2 & 3. It was found that the quantity and quality of the fog suffice for a water supply scheme. At a potential site for fog-harvesting near a Topnaar village, the daily average of fog water collected in the course of a year exceeds 1 litre/m<sup>2</sup>/day. Fog occurs throughout the year, but varies with season. On the ground, it comes from the NNE, running obliquely to the NW from which the cloud comes. Storm winds and variations in fog and in the water consumption affect the design of a water supply scheme. The costs of a fog-water supply scheme are similar to that of a wind pump, but it is a more sustainable and environmentally friendly water source.

Following the current fog water evaluation, more information transfer is taking place and a partnership is being formed with the rural community for the joint development of fog harvesting schemes. Fog water as a resource needs to go hand in hand with an integrated awareness of all natural resources and the need to manage them in a sustainable manner.

## Table of Contents

Summary.....	2
Table of Contents.....	3
Acknowledgements.....	5
<u>Funding</u> .....	5
Support, Advice & Guidance.....	5
Permission.....	6
MAP OF NAMIBIA .....	8
Section 1: Background and Summary of Findings .....	9
Introduction.....	9
Objectives of Phase 1.....	10
Summary of Findings .....	10
Fog Water Quantity .....	10
Fog Water Quality .....	11
Fog Climatology .....	12
Equipment Sturdiness .....	12
Water Needs Assessment.....	12
Informing and Training Fog Users.....	13
Social and Environmental Aspects .....	13
Designing a Fog-water Supply Scheme.....	14
Conclusions and Recommendations .....	14
Section 2: Namib Fog Climatology .....	16
Introduction.....	16
Methods .....	16
Spatial and Seasonal Variation of Fog.....	17
Surface Winds.....	18
Types of Fog.....	18
High Fog.....	19
Conclusions and Recommendations .....	21
Section 3: Quantity and Characteristics of Fog .....	23
Introduction.....	23
Methods .....	24
Study Sites .....	25
Results.....	28
Quantity of fog collected .....	29
Conclusions and Recommendations .....	39
Section 4: Topnaar Water Needs .....	41
Introduction.....	41
Methods .....	42
Current Water Supply .....	43

Water Requirements .....	43
Attitude towards Fog as a Water Source.....	44
Conclusion and Recommendations.....	44
Section 5: Designing a Fog-Water Supply System.....	46
Introduction.....	46
Water availability.....	47
Water consumption.....	48
Storage Capacity .....	49
Management of Consumption.....	51
Components of a fog water supply system .....	53
Detailed Design of the Elements.....	55
Costs .....	56
Environmental Effects .....	58
Conclusion and Recommendations.....	59
Section 6: Literature .....	60
Namfog Publications.....	60
Outputs of Namfog Phase I (Evaluation).....	60
References Cited.....	60



Ms. Cynthia Afrikaner, Namibian Department of Water Affairs, Windhoek

Ms. Elke Erb, Camel Farm, Swakopmund

Ms. Hermina !Narib

Prof. Percy Jiménez, Institute of Environmental Science, Universidad Nacional de San Agustín, Arequipa, Peru

Mr. Juan Ossandon, Fog Harvesting Project, El Tofu, Chile

Prof. Pilar Cereceda, Department of Geography, Pontificia Universidad Católica de Chile

Residents of Klipneus & Swartbank

## **Permission**

Ministry of Environment and Tourism (MET) gave permission for work in the Namib-Naukluft Park and supported the community interaction.

## Abbreviations

BSFC	Bidirectional Standard Fog Collector
DRFN	Desert Research Foundation of Namibia
DWA	Directorate of Water Affairs
ECEP	Environmental Capacity Enhancement Project
FCU	Fog Collector Unit
FDF	Fog Day Frequency
IDRC	International Development and Research council
MAWRD	Ministry of Agriculture, Water and Rural Development
MET	Ministry of Environment and Tourism
SFC	Standard Fog Collector
Vfb	Vogelfederberg

# MAP1

## MAP OF NAMIBIA

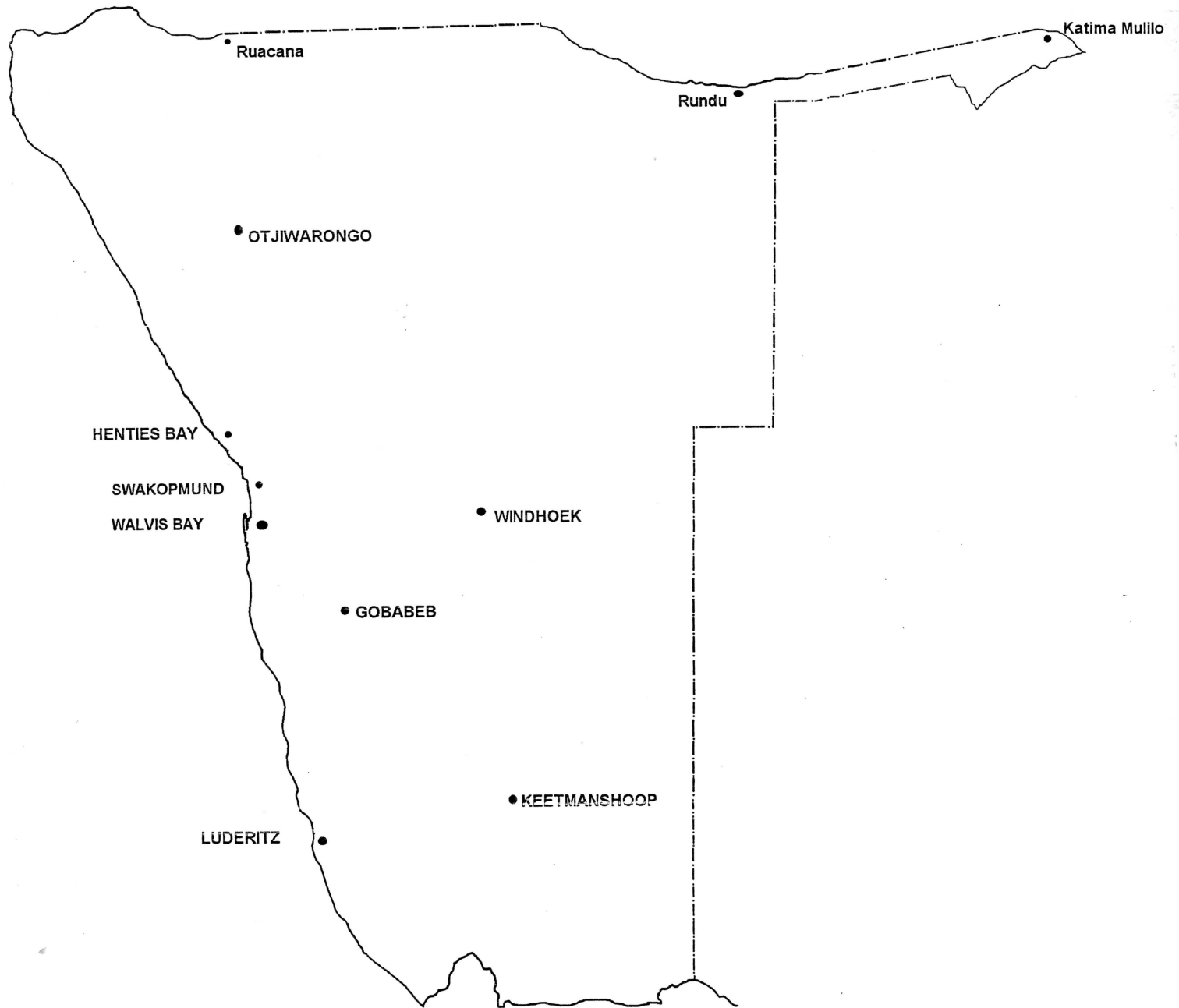



## Section 1: Background and Summary of Findings

### Introduction

Namibia is a desert country with a decreasing gradient of rainfall from NE to SW. The west coast is the hyperarid Namib Desert with no perennial rivers. The Central Namib Desert receives <22mm of rain and 30-180mm of fog per year. Fog occurs on 60-200 days per year, making it a predictable source of water with a coefficient of variation of 44% compared to 116% for rain (Pietruszka & Seely, 1985; Seely & Henschel, 1998). It is therefore not surprising that it is used by animals and plants (Seely, 1979; Seely *et al.*, 1998), and can be used by humans. Some 100 000 people live in the towns of Swakopmund and Walvis Bay, coastal towns and villages. The latter include small communities of indigenous people, the Topnaar, and the research and training centre at Gobabeb, situated in the desert interior. Potable water is obtained from groundwater via manually maintained wells, boreholes, and the Central Namib Water Scheme based on aquifers in the ephemeral rivers, the Kuiseb and the Omaruru (Dausab *et al.*, 1994; Jacobson *et al.*, 1995).

Groundwater reserves depend on input from rainfall in the >200km distant interior of Namibia's highlands. In recent years, water abstraction has exceeded input and the groundwater is being depleted. Alternative water supplies will be required. Fog water may have the potential to supplement small-scale users and can thereby contribute to alleviating the water deficiency along the Namibian coast (Nagel, 1959; Nieman *et al.*, 1978). A model case developed in Chile has demonstrated that this is possible (Cereceda *et al.*, 1992; Schemenauer & Cereceda, 1994a) and the Chilean experience has since been applied in Peru, Ecuador and Oman. Fog as an alternative water resource is presently gaining attention in many developing countries, including South Africa (Struthers, 1995, 1997; Olivier, pers.comm.), and, in the current case, Namibia.

Phase 1 of the DRFN's Namfog project entailed evaluating the potential for the rural Topnaar community to collect and use potable fog water. We investigated the occurrence, water content and climatological parameters and from this information, determined the yield of fog water as a fundamental premise to further objectives. Water needs and the social, environmental and economic considerations were taken into account in the preliminary design of a fog-water supply scheme for a Topnaar village to serve as a model for others. The experience gained with pilot schemes in the proposed Phase 2 will facilitate the further application of this technology in Namibia.

The current report meets Objective 8. In it we present the results of the first seven objectives of Phase 1 of the Namfog project, namely, quantifying the fog water yield, analysing its quality, testing fog-collecting equipment, assessing the water needs, informing and training potential water users, identifying the social and environmental factors concerning water use, and designing a fog-water supply scheme.

## Objectives of Phase 1

1. Quantify fog water yield with Standard Fog Collectors for one year in areas that can supply potential future users with potable water in the Central Namib Desert
2. Analyse water quality
3. Test suitability and durability of fog-collecting equipment, identify problems and test solutions
4. Assess local water needs
5. Inform, train and educate potential users and managers of potable fog water supply plants
6. Identify major social and environmental aspects involved in collecting, supplying and using potable fog water
7. Make preliminary designs of fog-water collection and supply systems
8. Produce a report that evaluates the potential of using fog water
9. Publish analyses of climatological data of Namib fog and results of the project
10. Disseminate the information appropriately
11. Plan phase II: pilot plant to supply indigenous village along the Kuiseb River
12. Suggest phase III: further studies to expand the application of this technology in Namibia

## Summary of Findings

### Fog Water Quantity

Fourteen Standard Fog Collectors (SFC, Schemenauer & Cereceda, 1994b) were placed at six sites near Topnaar villages along the lower Kuiseb River in the Central Namib Desert. SFC orientation was northwest. The SFCs were monitored manually or with data loggers between October 1996 and September 1997. Based on their physical characteristics, three sites near villages were selected for study, namely, Swartbank (altitude 332m above mean sea level (amsl); distance from sea: 37km; distance from village: 8km), Klipneus (altitude 340m amsl; sea: 46 km; village: 2km), and Soutrivier (altitude: 387 m amsl; sea: 53 km; village: 0.3km). These villages were chosen because of their need of water.

We found that the annual daily average quantity of fog water collected with SFCs was highest at Klipneus, where it exceeded 1 litre/m<sup>2</sup> of collector/day (Table 1.1). There was, however, considerable seasonal variation in the frequency and wetness of fog (Figure 1.1, Table 1.1).

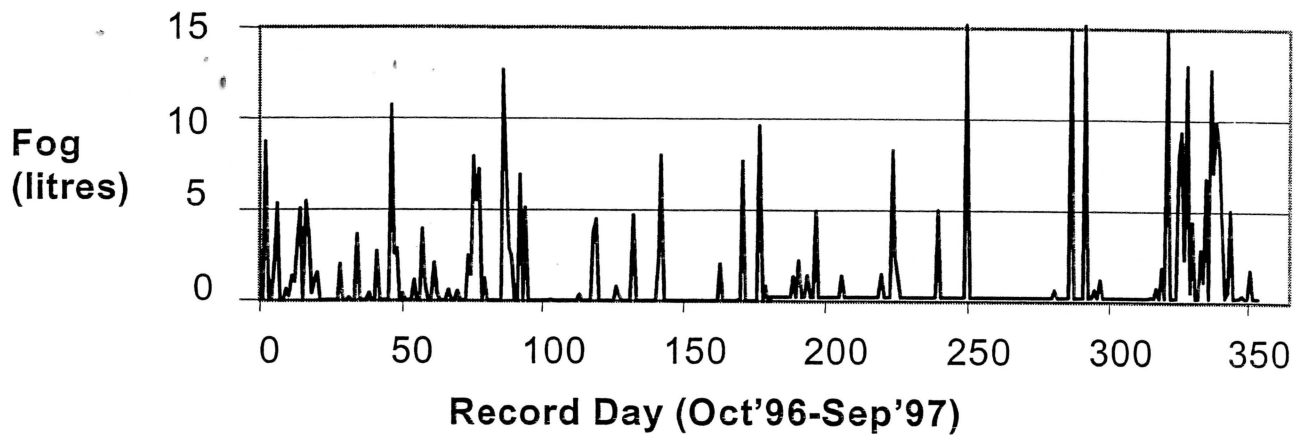

Figure 1.1: Quantity of fog recorded daily (litres/m<sup>2</sup>/day) over the course of 1 year at Klipneus.

Table 1.1: Fog records with SFCs at three Topnaar villages in the Namib Desert including manual and logger data.

Place	Swartbank	Klipneus	Soutrivier
<b>Number</b>			
record days	321	356	273
fog events	108	111	60
<b>Mean Quantity of water collected (litres / m<sup>2</sup>) per</b>			
per fog event	2.384	3.345	0.437
per day for one year	0.802	1.043	0.096
per day during Aug-Jan	2.720	2.122	0.704
per day during Feb-Jul	0.423	0.453	0.084

During the “wet” 6 months (August-January), fog occurred on 45% of the days, and the average daily yield >2 litres/m<sup>2</sup>/day. By contrast, from February to July, fog occurred on only 15% of the days, yielding <0.5 litres/m<sup>2</sup>/day. Swartbank was similar to Klipneus, but Soutrivier received much less fog.

## Fog Water Quality

Water samples were collected from SFCs at Gobabeb and were sent to the Department of Water Affairs for analyses. Although the fog water is quite pure and of neutral pH (Eckardt, 1996), the SFC screen accumulates dust and wind-blown salts that get washed off by the fog water. The initial rinse off the SFC after a non-foggy period yielded turbid, brackish water (1630 mg NaCl.l<sup>-1</sup>) that was only marginally fit for human consumption, but could be used for livestock. The subsequent water was considerably cleaner and of lower salt content (<1000 mg NaCl.l<sup>-1</sup>). Equally good quality fog water has been collected and analysed by Coetzee and Mulder (pers. Comm.) and Rössing Uranium Mine.

## Fog Climatology

The climatological mechanisms of Namib fog are complex. We examined the patterns that emerge from analyses of fog records made at a network of weather stations in the Namib over a period of 35 years. There are different kinds of fog. While the main fog at the coast is advective coming from the SW, the Namib interior is affected by a low stratus cloud that is transported inland from the Atlantic Ocean by a NW wind. The characteristic ground winds that precede the normal fog events in the interior are NW followed by a SE wind, which turns to NNE when the fog arrives (Figure 1.2). Weather stations thus record fog as coming from the NNE. This means that fog-collecting screens should face NNE

and that their deployment

in a NW direction during the current study underestimated the water yield.

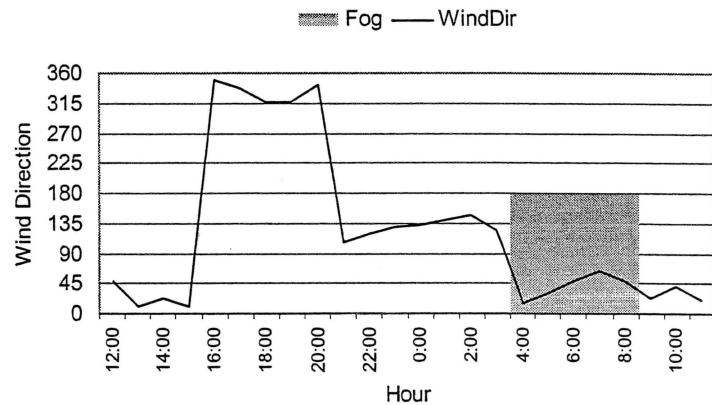

Figure 1.2: Time progression of wind directions recorded at Vogelfederberg prior to (clear) and during a fog event (shaded) on 17-18 April 1997.

## Equipment Sturdiness

The SFCs were observed during and after dry, strong storm winds that occur during winter. Such winds, with average hourly speeds exceeding 12-16m/s, gusting at an estimated 24-32m/s, occurred on twelve occasions during 1997. Several SFCs were damaged during winter storms and were strengthened with additional supporting structures. Some of the plastic logger equipment did not withstand this weather, resulting in data loss. We conclude that the fog collectors should be designed to withstand gusts of at least 35m/s coming from easterly to northerly directions.

## Water Needs Assessment

During winter and the summer school holidays we interviewed people at the three Topnaar villages of Swartbank, Klipneus and Soutrivier about their water sources and requirements and obtained information on the population sizes of the villages and associated domestic animals. We also recorded water management systems and estimated the volume of water from the size of the containers used to fetch or store it at the homes.

The water sources are traditional hand-dug wells of 5-15m depth in the riverbed. In addition, there is a wind pump at Klipneus and a diesel pump at Soutrivier, both of them installed and maintained by the Government. However, the pumps become unreliable when they are a few years old. The Swartbank people fetch a considerable proportion of their water with donkey carts from the 20km distant Utuseb school that gets its water from the municipal supply of Walvis Bay.

The total population of the three villages fluctuates between 35 and 92 people. Residents are occasionally joined by those working in town and school children. People use between 11 and 68% of the total water consumed, and the rest goes to domestic animals (goats, donkeys, cattle, dogs, poultry), with cattle requiring about half the water. The consumption fluctuates least at Klipneus (47%), and most strongly at Soutrivier (137%). The total volume of water consumption is highest at Swartbank (2.3-3.8m<sup>3</sup>/day), intermediate at Klipneus (1.2-1.8m<sup>3</sup>/day), and least at Soutrivier (0.7-1.6m<sup>3</sup>/day).

### **Informing and Training Fog Users**

The attitude of people towards fog as a potential water source is as important as providing the ability to access this source. In preparation for managing fog-collecting schemes, the people of Swartbank, Klipneus and Soutrivier gained access to information and possibilities for hands-on training and experience concerning this technology. We worked with Topnaar leaders towards a fully participatory relationship addressing fog harvesting as a component of sustainable resource management. The possibilities of forming water committees for each village, which is also promoted by the Department of Water Affairs, were discussed and these are in an early planning stage. Those residents who assisted actively in the project helped to explain the process to other villagers so that the technology is familiar to many Topnaars by now.

### **Social and Environmental Aspects**

People living along the lower Kuiseb River are in need of alternative water sources. However, following years of Government dependency, they seem to have accepted their daily struggle with the existing system as a way of life: they walk long distances to hand-dug wells that require much maintenance, while they wait patiently for a Government technician to arrive to fix a pump. On the other hand, they have expressed interest in a reliable system that they can maintain themselves with little effort. However, they currently have limited funding and do not intend to invest this towards a new water scheme, a service provided by Government now and in the past. The means to afford to run the fog harvesting technology would need to be developed through a lengthy participatory process parallel to and integrated with that of the Department of Water Affairs which is focused on fostering self-responsibility for the management of water as a resource.

Given a more reliable source of water, the Topnaars could diversify their activities such as create gardens or investigate tourism opportunities which should improve their living standards. People have indicated, however, that if they obtained more water, they would keep more goats and this could increase impact on the environment. There is a real need for careful management of fog water and integrated water and range management is also a stated objective of the Department of Water Affairs.

## Designing a Fog-water Supply Scheme

The above points were taken into consideration in designing a pilot fog collecting and supply scheme. The suggestion that the first experimental fog water supply scheme be constructed at Klipneus has been discussed by the Topnaar community, although a final decision is awaited. The lessons from this scheme would facilitate planning for the more complex situation at Swartbank. In the meantime, we have made a preliminary design for the Klipneus conditions based on the model at Chungungo in Chile (Cereceda *et al.*, 1992, 1996). This design assumes that fog water will become the only water source, although here a hybrid system may be more realistic. The following factors were taken into account for the design: a) seasonal variation in fog water availability, b) the effect of the storage capacity on water availability, c) the sustainable consumption rate without emptying the storage tank, and d) the ability to vary the consumption rate. The optimal magnitude of each factor was calculated. Most importantly, due to the intervals between fog events, the reservoir can frequently empty unless the consumption is managed. Ideally the water will be rationed, i.e. an adequate quantity be made available each day, which cannot be exceeded if a tap is inadvertently left open. The resulting design comprises the following elements:

- enough fog collecting units of 48m<sup>2</sup> each (modified after Cereceda *et al.*, 1996) to supply the average daily water requirements
- pipes and sedimentation tanks
- a reservoir to sustain consumers for up to 3 weeks without fog
- a tank to contain the daily ration of water for households as well as domestic animals other than cattle
- another tank for the daily water ration for cattle at times when the main reservoir is over half full; cattle require alternative water when the reservoir is less than half full.

## Conclusions and Recommendations

Fog has the potential of providing potable water to villages in the Namib Desert. This is possible only at places located less than 50 km from the Atlantic Ocean, where the average daily yield is >1 litre/m<sup>2</sup>/day. In partnership with the Topnaar community, an experimental pilot plant should be built and managed at a village such as Klipneus. Important factors that influence the construction are the seasonal fluctuations of fog water supply and of its consumption as well as the occurrence of dry storm winds. It is very important that water consumers adopt the idea that fog is a resource that they can use sustainably.

Other methods of fog collection are being examined at Gobabeb and elsewhere in the Namib (DWA; Coetzee & Mulder, pers.comm.) as possible alternatives to the Conaf design used at Chungungo, Chile, that serves as our initial model. Fog harvesting should be considered in conjunction with other water sources and hybrid systems may be better than specialised ones.

Other uses of fog water should also be considered. For instance, if the indigenous !Nara plant is supplemented with water, it may increase the harvest of melons for the Topnaars (Dausab & Henschel, 1997). People in the coastal town of Swakopmund are investigating the possibility of watering vegetables with fog water (Coetzee & Mulder, pers.comm.). Indeed, fog water could turn out to be a valuable supplementary water source to help alleviate the water shortage along the Namibian west coast (Afrikaner, 1998).

A better understanding of the mechanisms and behaviour of fog is required in order to optimise the collection method, place and time, and to be able to improve the prediction of this source of water.

## Section 2: Namib Fog Climatology

### Introduction

Ten to seven million years ago the cold water upwelling system of the Benguela current was established on the east side of the Atlantic Ocean and heralded the approach of the current Namib Desert phase. The hyperaridity of the Namib Desert can be ascribed to its proximity to the low sea surface temperatures of the Benguela-upwelling system and Namibia's latitudinal position within the subtropical high pressure zone. These factors are, amongst others, essential for the formation of coastal fog. (Olivier, 1992). The Central Namib is essentially a flat plain with a gradual slope of 5-8 m per km up to the foot of the Great Escarpment. Despite a few isolated Inselbergs and dunes, there are few major landscape features that would influence the macro-climate. These physical characteristics make the Namib unique among deserts of the world (Taljaard, 1979).

Fog is important in the Namib. It affects the climatic pattern of the western part of the desert (Schulze, 1969; Seely & Stuart, 1976; Lancaster *et al.*, 1984). Its precipitation is five times greater than that of rain and it is much more predictable than rain (Pietruszka & Seely, 1985). It is therefore not surprising that fog serves as a major water source for lichens, plants and animals that could otherwise not occur in this area (Seely, 1979; Seely *et al.*, 1998) and it may also affect geological processes (Martin, 1963; Goudie, 1972; Eckardt, 1996). Changes in fog patterns, possibly caused by El Niño events or global climate change, could have major implications on the availability of this important source of water in the desert.

Measurements of Namib fog have been conducted with standard meteorological recorders at Gobabeb since its inception. A variable network of such gauges has been used over an area of 20 000km<sup>2</sup>. The DRFN recently conducted a project to evaluate the possibility of harvesting fog water (Mtuleni *et al.*, 1998). This project emphasised the need to understand the patterns and dynamics of Namib fog. In the current paper, we describe the various types of fog in relation to wind patterns and we present hypotheses on the dynamics of the fog types. This is done by drawing on previous literature as well as examining the initial results of our ongoing analyses.

### Methods

Between 1962 and 1996, the weather station at Gobabeb used a cylindrical wire mesh screen (10 cm diameter, 22 cm height) above a rain gauge to collect fog and data were recorded on a chart. The autographic weather station also had an anemometer and thermohygrograph. Similar weather stations were situated at nine places (Lancaster *et al.*, 1984), of which four are still maintained, namely, Gobabeb, Kleinberg, Vogelfederberg (Vfb), and Ganab. In 1990-1993 they were furnished with electronic data loggers. During 1997, these were fitted with Standard Fog Collectors (Schemenauer & Cereceda, 1994) which correlate with the cylindrical collectors ( $r^2=0.62$ ).



Olivier (1992, 1995) attempted to use remote sensing to study the spatial distribution. However, satellite imagery does not reveal precipitating fog in the Namib (Gut & Seely, in prep.) nor elsewhere (Gurka, 1975). Furthermore, our hourly records of fog precipitation at weather stations show that some fog events occur only at night. Satellite imagery is therefore not a good correlate of fog precipitation, but can be used to study the extent of cloud cover over the Namib.

### Spatial and Seasonal Variation of Fog

Olivier (1992) showed how stratus clouds penetrate from the Atlantic up to 100km into the Central Namib. There are indications that these clouds are associated with the upwelling cell off Walvis Bay (Shannon, 1972; Shannon *et al.*, 1989; Olivier, 1995) from which they drift inland. The frequency of stratus cloud cover declines from >100 days at the coast to <10 days at 100km inland.

Lancaster *et al.* (1984) indicated how fog precipitation changes from the coast inland (Table 2.1). There was an increase in the fog day frequency and in fog precipitation from the coast to 20-60km inland beyond which the fog declined. Highest precipitation was at two stations situated at altitudes of 340 and 500m amsl (altitude above mean sea level) at distances of 33 and 60km from the coast.

The monthly distribution of fog differs between the coastal and inland areas (Nieman *et al.*, 1978; Lancaster *et al.*, 1984). At the coast, the peak months are May - September, while inland the peak months are around August - October with a secondary peak around March.

Table 2.1: Average fog day frequency (FDF) and quantity of fog (ml) recorded with cylindrical screens at seven locations along two transects monitored for 3-15 yrs (after Lancaster *et al.*, 1984).

Place	Distance (km)	Altitude (m amsl)	Annual Fog	
			FDF	ml
<b>Transect 1 (across gravel plains)</b>				
Swakopmund	1	20	65	34
Vogelfdrberg	60	500	77	183
Ganab	120	1000	3	3
<b>Transect 2 (along Kuiseb valley)</b>				
Rooibank	18	63	76	80
Swartbank	33	340	87	183
Gobabeb	56	407	37	31
Zebra Pan	106	780	16	15

## Surface Winds

There are many complex factors influencing the wind direction and consequently the fog transport with respect to season, time of day and topography. There are also differences in the wind regimes between the coastal and inland areas. Winds at the coast are predominantly SSE–SSW throughout the year (40-50% of the time), while N and E winds occur for 8-10% of the time.

Four winds predominate in the interior of the Central Namib (Tyson & Seely, 1980; Lancaster *et al.*, 1984; Lindsay & Tyson, 1990).

- A SW sea-breeze (5-10 m/s) occurs throughout the year with peaks in September and March. It begins at the coast during the late morning and can penetrate inland across the entire Namib by evening, typically ceasing at nightfall. The strength of the sea-breeze declines with distance from the coast.
- A fairly strong (10-15 m/s) NW plain-mountain wind begins in the late afternoon and continues until around midnight. This wind is driven by a thermal gradient between the cool western part of the desert and the hot eastern part. This wind dominates in summer and often undercuts the sea-breeze.
- The counterpart of the plain-mountain wind is the moderate (5-10 m.s<sup>-1</sup>) SE mountain-plain wind that begins at night and peaks at sunrise. This wind is driven by a reversal of the thermal gradient caused by the eastern part of the Namib, cooling more rapidly under a clear sky than the coastal region and ocean. Mountain-plain wind strengthens in winter.
- Occasionally during winter, very strong, dry easterly berg winds (Föhn) interrupt the pattern of the other three winds.

Topographical differences can also influence local winds. In the Kuiseb valley some topographic funnelling occurs, changing the local wind direction (Lancaster *et al.*, 1984). This funnelling of north-westerly winds creates a local wind up the Kuiseb valley on summer mornings.

## Types of Fog

At the coast, the dominant wind direction during fog on the ground is SW; it changes to NW at 20 km away from the coast and to NNE beyond 40km. This reflects changes in the fog types occurring in the Namib.

It has been recognised for some time that the Namib has several kinds of fog (Taljaard, 1979; Lancaster *et al.*, 1984; Vendrig, 1990; Olivier, 1995) including advective, radiation, and frontal fog, as well as intercepted clouds or high fog.

- Advective fog arrives at the coast during the afternoon with the southwesterly sea breeze. This fog is usually <200m high and occurs mainly within 15km from the sea for >100 days annually (e.g. all 15 fog events recorded near Wlotzkasbaken during August 1997 were accompanied by SW wind). On rare occasions, it can penetrate as far inland as Gobabeb. Advective fog forms when moderate southwesterly wind transports

humid air from the Atlantic across the cool Benguela current.

- Another type is frontal fog with drizzle that can accompany cold fronts for some distance across the Namib coast, but this is a relatively infrequent phenomenon (Vendrig, 1990; pers.obs.).
- Occasionally radiation fog develops, most likely when clear, moist coastal air meets the cool easterly mountain-plain wind, mixes, and forms a cloud at ground level (Jackson, 1941; Nagel, 1962; Vendrig, 1990; Olivier, 1995; Eckardt, 1996; pers.obs.).

## High Fog

In the Namib interior, the major source of fog are low clouds that intercept the land, called high fog which is a low stratus and strato-cumulus cloud that is formed by vigorous air turbulence over the Benguela current (Lancaster *et al.*, 1984; Vendrig, 1990; Olivier, 1995). The resulting cloud sheet is situated at 100-600m height below a strong inversion layer. It is transported inland by a northwesterly wind, possibly enhanced by the plain-mountain wind. Depending on its height, the low stratus cloud may intercept the land at 20-120km inland (and sometimes even reaches the escarpment), but its interception area is most frequently situated between 20-60km from the coast (altitude 200-500m amsl). Weather stations usually record this fog with fairly strong wind (>10m/s) from NNE (Fig. 2.1).

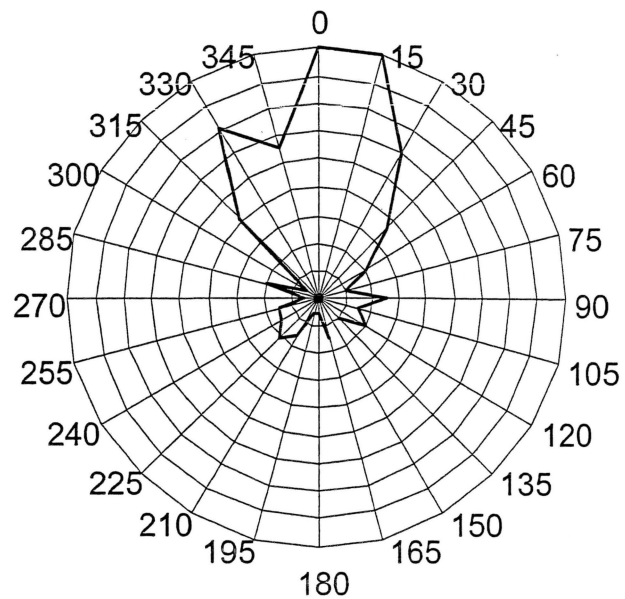

Figure 2.1: Wind direction during fog events at Gobabeb in 1997. Each circle marks 2 events.

The NNE fog direction is preceded by northwesterly wind, often with a SE wind between the NW and NNE. We interpret these observations as follows. Easterly mountain-plain wind rises during the late hours of the night and this cool air mass hugs the land on its way to the coast. The stratus cloud, coming from the northwest, penetrates this air mass coming from the east, while the stable inversion may prevent the cloud from rising above this layer. Mixing occurs and the resultant wind direction is NNE. This direction is oblique to the isobar from the

interception point with only a slight decline in altitude as the fog progresses. The fog thus has a different direction on the ground than the higher winds that transport the cloud that feeds it.

This hypothesis is supported by records of the wind direction switching within hours from NW (plain-mountain) to SE (mountain-plain) before the weather station records fog from NNE (Fig. 2.2). This was also illustrated by Lancaster *et al.*, (1984; p. 25: Fig. 39 & 40) and Lindsay & Tyson (1990; p. 68: Fig.5a-top).

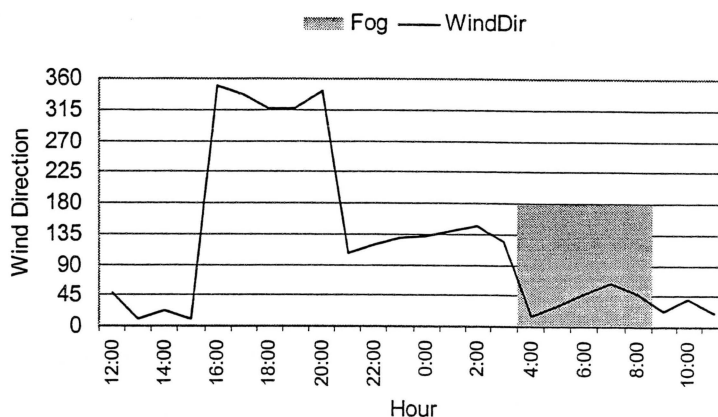

Figure 2.2: Time progression of wind directions recorded at Vogelfederberg prior to (clear) and during a fog event (shaded) on 17-18 April 1997.

Ongoing monitoring at the DERU weather stations confirms that this is the normal succession of wind directions (e.g., in 74% of the 65 events recorded in 8 months at Vfb in 1997, and nearly all of the events with  $>0.6$  litres.m<sup>-2</sup>). The E-SE wind intervening between the NW and NNE winds was of variable duration (0-8 h). The marine origin of the low stratus cloud that forms the interception cloud is well-established (Jackson, 1941; Lancaster *et al.*, 1984; Olivier, 1995). Its content of dimethyl sulphide, formed by marine phytoplankton, appears to reflect this (Eckardt, 1996). Furthermore, a marine origin is consistent with the appearance of this cloud on satellite images (Olivier, 1992). The occurrence of high fog is independent of advective fog at the coast and the two types of fog can simultaneously occur at different altitudes (Olivier, 1995; pers.obs.).

The seasonal distribution of peak periods of high fog around September and March is consistent with the association of these fog events with both plain-mountain (NW) and mountain-plain (SE) winds. Plain-mountain winds are weak in mid-winter (May-July), and mountain-plain winds weaken in mid-summer (December-February) (Lindsay & Tyson, 1990), and both wind types are well developed during the peak fog period. There may also be seasonal variations in the development and the height of stratus clouds formed at sea. The climatic mechanisms of stratus cloud formation and transport beg study.

The observed direction of the fog is consistent with the spatial distribution of the fog precipitation. Although Vfb lies much further from the coast than Swartbank, the precipitation is similar (Table 2.1). The directional line joining these places is NNE and fog that crosses Vfb moves directly towards Swartbank. By contrast, Gobabeb is situated at a similar distance from the coast as Vfb, but receives much less fog.

This leads to the conclusion that the fog isohyets cross the interior of the Central Namib in a NNE direction and that they descend obliquely in altitude. This may explain why Hachfeld (1996) measured some rather wet fogs at a distance of 90km from the sea (altitude 800-900m) along a transect running along the Swakopmund-Usakos road, at a site 100km NNE of Vogelfederberg (130km NNE of Swartbank). By contrast, indications are that at 90km from the sea along the Kuiseb river there is likely to be very little fog precipitation (compare Swartbank-Gobabeb-Zebrapan in Table 2.1). The profile is unknown east of Vogelfederberg (Ganab is too far for comparison). We would gain a better understanding of the behaviour of the fog cloud if weather stations are set up (again) at Swartbank and near Kriess-se-Rus (25km W of Vogelfederberg). Kriess-se-Rus is thought to have similar fog conditions to Gobabeb, and Swartbank to Vogelfederberg. Weather stations with loggers could follow the fog events from one station to the next, not along a NW-SE path, as previously suggested, but along a NNE-SSW path.

We suggest that the patterns of the fog can be explained as follows. NW winds transport the stratus cloud inland. The height of this cloud is limited due to the strong inversion layer, and this also prevents the cloud from moving uphill when it meets land. The central Namib slopes downwards in a ENE-WSW direction so that the cloud, coming from NW intersects it at an angle. The front of the cloud, prevented from moving uphill, turns southwards along the contour lines (the wind direction would be NNW), but progressively stronger SE winds (mountain-plain) turn the front of the cloud even further around so that it moves towards SSW (its wind direction being NNE).

## **Conclusions and Recommendations**

There are two major types of fog in the Namib, namely the coastal advective fog, and low stratus cloud that is intercepted inland, also called high fog. Although the advective fog occurs frequently, its precipitation of water is only moderate and SW wind speeds are mild. By contrast, the high fog involves the dynamic interaction of two air masses, causing an oscillation of wind directions from NW to E, and then to NNE when the fog arrives. High fog results from a low stratus cloud of 100-600m high that moves from the Atlantic Ocean across the Namib in a NW direction until it intercepts the easterly mountain-plain wind, mixes with it and precipitates as fog. Two other minor fog types of the Namib are radiation and frontal fog.

The importance and the nature of the high fog have often been overlooked. For instance, we mistakenly oriented a network of SFCs towards NW based on the general belief that inland fog comes from this direction (Mtuleni *et al.*, 1998). We now suggest that an orientation of the SFCs to NNE (or N) would substantially increase the yield. This would increase the viability of potential fog water supply schemes at Topnaar villages. Furthermore, the knowledge that the coastal fog may differ fundamentally from the inland fog studied by Mtuleni *et al.* (1998) supports the need for a separate evaluation of the potential of harvesting the coastal fog. Some previous authors may not have distinguished between the coastal and the inland fog types.

The climatology of Namib fog may not have enjoyed the attention it warrants because of the depth of understanding that has been gained in detailed studies of fog in the cross-continental South American counterpart (Schemenauer *et al.*, 1988; Cereceda & Schemenauer, 1991). The indications are, however, that there are important differences, and that the Namib fog may be more complex than previously believed. The high fog of the Namib warrants much more detailed study than it has received to date, especially if there are intentions to tap this water source more extensively. The Desert Research Foundation of Namibia wishes to invite climatologists to improve the understanding of Namib fog.

## Section 3: Quantity and Characteristics of Fog

### Introduction

When determining the potential of using fog as a water source it is most important to find out the yield of water from fog at locations close to the potential users. The quantity of fog water collected per unit area of collector and its distribution over time (days, months, seasons, years) determine the technical side of a water supply scheme (see Section 5).

In the landmark studies conducted by Pilar Cereceda and Bob Schemenauer in Chile, they describe the important information and methods of obtaining information that enable one to design a viable fog water supply scheme (Schemenauer *et al.*, 1988; Cereceda & Schemenauer, 1991; Cereceda *et al.*, 1992, 1996; Schemenauer & Cereceda, 1994a, b). The initial technical decisions concern the most suitable site for harvesting fog near a target site where the water is required. While the terrain and the macro- and microclimatic conditions influence the decision of where to locate a test site, the Standard Fog Collector is used to determine the quantity of fog water at that site. Ideally, at least some SFCs in a region are fitted with data loggers that record wind speed and direction as well as rainfall and, if possible, temperature and relative humidity. The distance to the target site is a consideration. At El Tofo in Chile, which serves as the model case for the current study, a viable fog water supply scheme is situated 8km from the water users at Chungungo. Residents of that town maintain the fog collectors, using cars to commute.

In Namibia, Topnaar residents at rural villages walk or use bicycles or donkey carts as transport. As it is necessary for the people to take care of their own fog collectors, it is highly desirable to find the closest possible site with enough fog. The topography, general knowledge of fog, as well as biotic indicators such as lichen or fog-utilising plants such as *Arthroerua leubnitziae* determine the initial choice of site.

The aim of the current survey is to find factors influencing the occurrence of fog and the best conditions for collecting fog precipitation in Namibia. There are many conditions that have to be studied and this survey sets itself the task of investigating them and seeing whether a fog-harvesting project would be applicable to the conditions in Namibia.

## Methods

**Study Period** Fieldwork was conducted between October 1996 and December 1997. Monitoring is continuing at some sites. Most data that were used for analyses are from the year October 1996 to September 1997.

**Fog Collector** The Standard Fog Collector (SFC; Schemenauer & Cereceda, 1994b; Appendix 2) comprises a double-layer of Rashel-type polypropylene shade netting spanned over a 1m<sup>2</sup> frame, with the base fixed at a height of 2m above the ground. The net's polypropylene fibres cover 35% of the total area and in SFC a double layer of mesh is used, which gives a higher yield. This mesh covers roughly 60% of the collector's surface and leaves around 40% of the area free for the wind carrying the water drops to pass through. The vertical zig-zag weave of the Rashel mesh is important as this structure does not hold the collected water, but allows it to run downwards. An alternative 3-dimensional cubically-woven mesh made by Kimre was also tested alongside the Rashel-type screens of the SFCs. This captured less fog water than the Rashel mesh, on average only 44%, but its relative efficiency improved during wet fog events, when it yielded 93% as much water as the Rashel mesh. During the rest of this study, all measurements were made with Rashel mesh, which is currently used for international comparison.

A gutter below the frame collects the water and channels it through a hose to a water storage container, which is monitored manually by emptying into graduated cylinders. The hose may be interrupted by a small Rain-O-Matic analog water gauge connected to an Adtron data logger to record the quantity of water collected ( $\pm 0.5$ ml). An anemometer with wind direction sensor was fitted 0.5m next to the screen. The data logger recorded the quantity of fog (ml/m/h) and the average wind speed (m/s) and direction ( $\pm 45^\circ$ ) for each hour.

All the SFCs were oriented towards NW. This was based on the initial supposition that most fog comes from this direction. This was the agreed-upon direction for all SFCs used in the Namib by the DRFN and the DWA since the middle of 1996. It should be pointed out here that this assumption was not correct and modifications have been suggested (see conclusions of Section 2 and Appendix 3).

**Data Logger** The Data Logger connected to the SFC records the amount of collected fog, wind direction and wind speed on an hourly base. The anemometer/wind vane is situated next to the screen. With this information we were able to survey correlation between fog occurrence and wind patterns. Wind is important because of its role of transporting the fog from its source inland to the SFC sites and is pushing the fog through the mesh of the SFC.



## Manual Measurements

The manual measurements were carried out on a daily base. At Gobabeb we observed different possibilities of fog collecting and were able to link this information with the data from the First Order Weather Station. At other sites the manual results were more of an addition to the information from the data logger, or a supplement to test the micro-variation between the sites in an area. They also served as a backup for instrument failure of data loggers. Manual monitoring consistently measured  $83.1 \pm 6.8\%$  less fog water than the loggers and consequently this figure (multiply manual by 1.203 for actual volume) was used to compensate for the losses (evaporation, spilling, retention of water in 25-l container).

## Difficulties

It was not possible to obtain data for the data loggers continuously over the entire year from all sites. A check of all sites could only be made once a month due to the distances involved. If technical difficulties did arise within that month, data were lost. The accuracy of the wind data gathered is also questionable, as the plastic anemometers and wind vanes were not robust enough for Namibian conditions. As a result, problems were encountered in resetting the loggers after changing the batteries. All wind data at wind speeds  $<1.5 \text{ m.s}^{-1}$  were ignored due to resistance within the instruments. Several of the plastic anemometers broke in very strong winds within the first weeks of use and we consequently obtained no data on wind from several sites.

Alois !Narib, the field assistant who is a pastoralist at Klipneus, had to cover a substantial distance on foot and by bicycle to measure the fog at Swartbank. It was not possible for him to measure the amount of fog there every day. Because the top of the Swartbankberg receives so much fog, the 25-l container frequently overflowed. For this reason, we do not have exact information on the two manually measured sites (southern peak and central western edge of the middle plateau) on the Swartbankberg.

## Study Sites

For this survey, the small rural settlements along the Kuiseb in the interior of the Namib Desert were selected. Fog occurs most frequently in the coastal regions but its effects have been noted up to 100km inland (Section 2). All settlements investigated during the current study are located within this fog belt and are 20-60 km from the coast. We selected suitable fog collecting sites within a certain radius of the settlements along the Kuiseb (Appendix 5). The physical criteria for selecting the sites were altitude and exposure to fog-bearing winds. It is necessary to gain a general overview of the climatic conditions in the entire Namib area to be able to select specific sites with the necessary conditions for collecting fog.

MAP 2: STUDY SITES

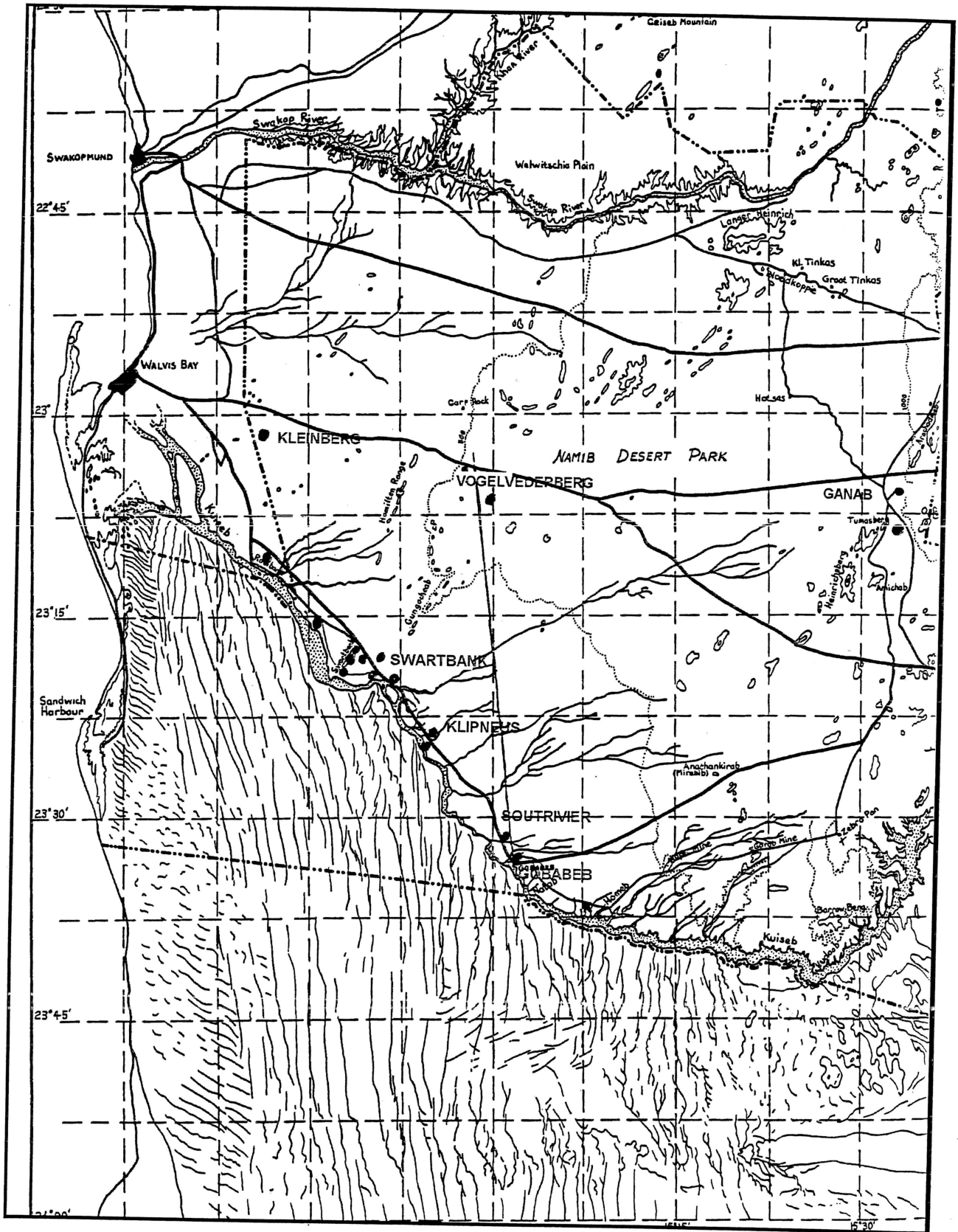

**Gobabeb** To get detailed data of fog and the related conditions in the Namib, daily observations and detailed recordings at the Gobabeb Desert Research Station were necessary. Gobabeb (23° 34' S, 15° 03' E) is located at an altitude of 408m above mean sea level (amsl) and 56km from the coast. Because of this distance it is not the best location to study fog, but there are permanent staff to do the detailed observations and to conduct experiments.

An SFC with a data logger is situated next to the first order weather station. Next to the SFC is a Kimre-type fog screen. The fog collected from this screen was measured manually. Manual measurements were also taken from an SFC situated on top of the 20m high water tower at Gobabeb and from the roofs of the research station buildings via a small free-standing 1m<sup>2</sup> galvanised iron cone (nicknamed "Chinese Hat") and compared. For comparison to these methods, a Norwegian-built experimental fog-collecting water pyramid ("Desert Rose") was placed next to the weather station.

**Soutrivier** This village is approximately 5km west of Gobabeb (23° 32'S; 15° 02'E). Because of its distance from the sea and proximity to Gobabeb, there is only one manual SFC placed on a hill above the settlement. This SFC was compared to that in Gobabeb.

**Klipneus** Klipneus lies 36km downriver of Gobabeb (23° 23'55.9"S; 14° 54'07.0"E). It is located 46km from the coast at an altitude of 352 m amsl. The Namfog field assistant Alois !Narib is a permanent resident of Klipneus and was responsible for the manual measurements of the SFCs in the vicinity of Klipneus and Swartbank. He also served as a liaison between the community leaders and the project leaders at Gobabeb. As Alois has an extensive knowledge of the fog project he is able to impart the relevant information about the project to the community.

There are two sites with SFCs at Klipneus. One is situated alongside the river and the other is on a hill, at an altitude of 360m amsl. The SFC on a hill 3,2km north of the village (called "Klipneus Top"; 23°22'11.5"S, 14°54'36.7"E) is equipped with a data logger, and in addition, the amount of collected fog was measured manually. This gave a backup measurement to that made by the data logger. The addition of manual data was very important to fill some gaps of the data logger data due to technical problems. The Klipneus Top site served as reference point to compare different localities during this study.

**Swartbank** Swartbank lies 45km downriver of Gobabeb (23° 24'S; 14° 54'E) 38km from the coast. This area has several topographic features. The settlement, at an altitude of 306m, is situated next to the Swartbankberg with its peak at 464m amsl. The proximity to the sea and the altitude make it an extraordinary site for collecting fog. The problem with situating a fog collection system on the top of the mountain is that it lies 10km from the settlement and the potential users and that large collectors would interfere with the aesthetic setting of this inselberg in a National

Park. An SFC equipped with a Data Logger is situated closer to the settlement at the base of the ridge, 320 m amsl. Two more SFCs are placed in more prominent positions on the Swartbankberg. One is installed on the southern peak, 420m above sea level. The other is situated on the central western edge of the middle plateau, 430m above sea level.

**Utuseb** In order to inform school children, one manually-monitored SFC was placed next to the J.P.Brand School at Utuseb. This school receives water from the municipal water supply of Walvis Bay.

**Rooibank** One SFC equipped with a data logger is situated next to the waterworks at Rooibank. There is no settlement but this site was chosen because of its proximity to the sea and the presence of staff of the Water Works of the Walvis Bay Municipality.

## **Results**

### **Fog water supply**

The hourly raw data from the data logger and the daily raw data from the manual measurements facilitated a daily, monthly and seasonal analysis of the occurrence of fog. The SFC at Klipneus Top was the most successful fog collection site of this survey. The data available spanned an entire year (October 96 – September 97) except for a gap in July. By contrast, there were longer gaps at Gobabeb and at Swartbank, both of which yielded less water than Klipneus. The total volume recorded by data loggers during the one year period from October 96 till September 97 differed from 32 753ml at Klipneus, 24 137ml at Swartbank and 2 487ml at Gobabeb.

### **Klipneus**

The good, continuous database as well as the highest amount of collected fog near a Topnaar village, make Klipneus a very important site for the current analysis. Klipneus was used as a reference against which data from other sites were compared.

## Quantity of fog collected

The total volume of fog water collected with an SFC at Klipneus Top during the one year period of measurement (Oct 96 – Sep 97) was 32 753 ml per square meter. The Data Logger operated for 305 days with an interruption in June/July. During the operational period, 99 fog days occurred with an average of 330ml per fog event, giving annual average per record day of 1 070ml per m<sup>2</sup>.

The maximum collected fog at Klipneus was 14 658ml on August 26, 1997. During the same day, the hourly peak was 4 310ml at 17H00. Despite such an extreme peak, the fog occurrence and the collected water are relatively balanced as is shown in Fig.3.1. There are seasonal differences in fog occurrence and the amount of collected water.

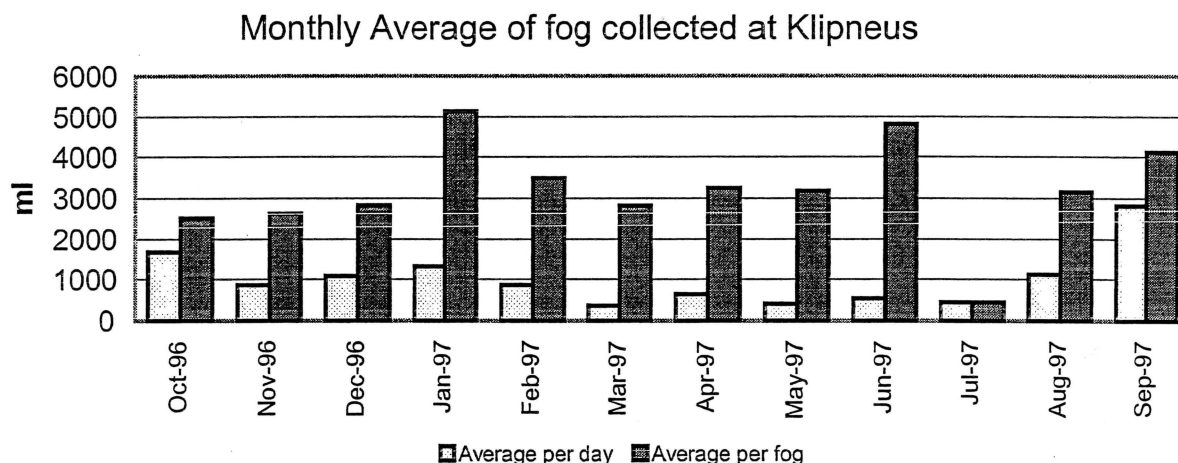

Figure 3.1: Comparison between the monthly average of the volume per fog and the volume per record day during one year

The interruption in June/July as seen in Fig.3.1 is caused by the missing data for this time. Manual data indicated that several fog events occurred during this period. There is thus a relatively continuous fog water supply per record day between 362ml in March 97 and 2 081ml in September 97. One unusually wet month was September 1997. During this month, 19 fog days were recorded with an average of 4 120ml per fog event. Another good month was January with 8 fog events and the highest average of 5 120ml.

### Seasonality

In the period from October 1996 until February 1997, when there was an average of 10 fog events per month, there was a good correlation between the average amount of water per fog event and the average per day. During this time the average amount of collected fog per day fluctuated between 1 674ml in October 1996 and 872ml in February 1997. Likewise, the results from August 1997 onwards were good, with a daily average

amount of 1 121ml in August and 2 801ml in September. In October 1997, following the one-year survey, only five fog events were recorded, but with an extremely high average of 7 208ml per event.

There were also periods in the year when the correlation between fog events and the amount of water collected per fog event was not that high. Between March and May 97 there were fewer fog events and the daily average fluctuated between 362ml in March and 649ml in April. It was not possible to get detailed data between June and July due to technical failure of the data logger and it was necessary to fall back upon data collected manually. These results show a moderate daily fog water supply of 661ml in June 97 and 1 001ml in July 97.

Looking at the seasonal variations, it is possible to subdivide the year into a wet foggy season and dry foggy season as well as transitional periods. The foggiest time of the year is during summer, from September until March. During this time the average fog amount per month is never under 850ml a day. The conditions change to a less foggy period in March with an average that is quite substantially less than 650ml. These conditions last until the end of May. June and July seem to be transitional months with an average ranging between 500 and 1000ml. The average amount of fog water collected rises above 1000ml in August and rises up to 2 800ml in September.

#### **Fog events**

Despite variations during the year, fog does occur throughout the year and they were mostly wet episodes. In 60.6% of all 111 fog events, the amount of water exceeded 1 litre. The longest period with a steady supply of fog exceeding 1 litre per event and occurring every day or every second day, was 10 days in October 96. The longest duration without fog which produced 1 litre or more, was for 17 days in March 97.

#### **Influence of Wind**

Despite technical difficulties with the wind measurement, the dependence of fog events on wind direction could be demonstrated. Only events with wind speed exceeding  $1,5 \text{ m.s}^{-1}$  are analysed. Some of the measured fog was transported by westerly winds. The SFCs are oriented NW, but, as shown in Fig.3.2 almost the same number of fog events occurred from SW directions. However, most fog events came with NNE and easterly winds. During the course of the study year it seems that the fog was brought from nearly all directions except from two directions ( $195^\circ$  and  $345^\circ$ ). This extraordinary result could be due to the effect that the SFC screen has on the anemometer situated 0.5m next to it.

### Fog Volume per Wind Direction

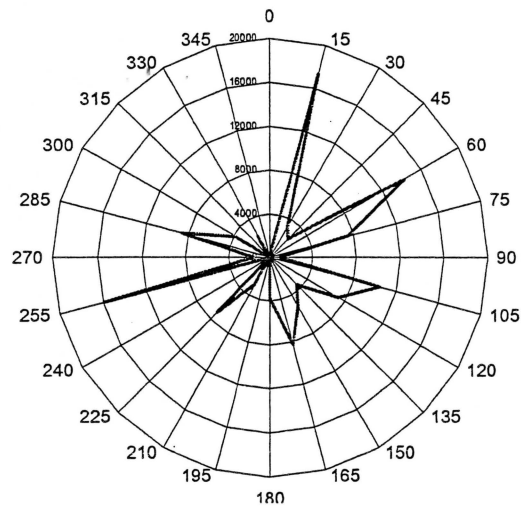

### Fog Events per Wind Direction

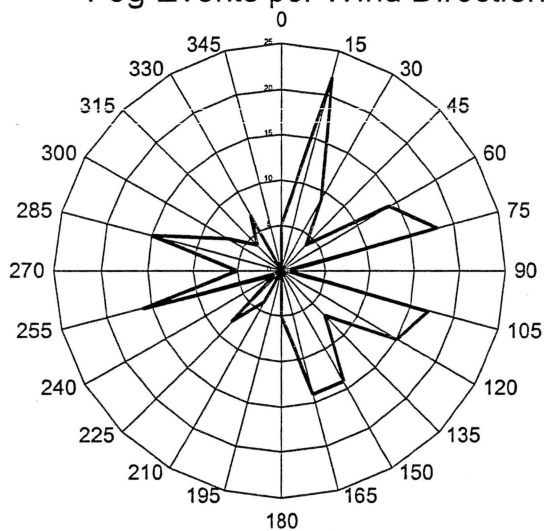

Figure 3.2: Sum of all fog events (lower) and of the volume of collected water (upper) per wind direction (grouped into 15°) during Oct 96 and Sep 97 at Klipneus.

When comparing the left and right parts of Fig.3.2, it can be seen that the results of fog events per wind direction and the volume of collected fog per wind direction have a similar distribution. Some water was collected in all directions, but the wettest events were in the NE sector. When analysing the total fog volume per wind direction during one year, it was found that 63.8% of the fog volume was transported by easterly winds (i.e. every wind direction between 0° and 180°) and the most from more northerly winds. Only 36.2% was transported by westerly winds (i.e. every wind direction between 180° and 360°).

In summary, fog at Klipneus was recorded from almost every wind direction, but there may be problems with the instrumentation. It is difficult to interpret the yield of collected fog reaching an SFC at an oblique angle and it is suggested that more data are required for the site with different instrumentation and possibly using a bi-directional SFC (BSFC; Cereceda *et al.*, 1996). In the meantime, the preferred direction would be northerly, more precisely NNE, in line with the data obtained from other weather stations elsewhere in the Namib.

Taking all these results into consideration, Klipneus is an acceptable site for a relatively reliable fog water supply, making it a good candidate for a water supply scheme.

### **Swartbank and Gobabeb**

We compared the differing conditions at Gobabeb and Swartbank with those of Klipneus. Data loggers were different at these sites: while the Adtron logger recorded fog, wind speed and wind direction at Klipneus, it recorded only fog precipitation at Swartbank. At Gobabeb, the SFC was connected to a weather station MCS-430. (Mike Cotton Systems, Steenberg, South Africa)

### **Quantity of fog collected**

The quantity of fog differed between the sites, normally being highest at the Klipneus SFC, intermediate at Swartbank, and lowest at Gobabeb (Table.3.1). The total quantity of fog recorded at Swartbank during the whole year was only 73.7% of that at Klipneus. Gobabeb yielded only 7.6% of the quantity collected at Klipneus. There were also slight differences between the different sites during different seasons. For instance, there was a relatively higher fog amount at Swartbank during February 1997. While September 1997 was the maximum month at Klipneus and Swartbank, it was January 1997 at Gobabeb.

*Table 3.1: Number of record days and fog days, and the quantity of fog per record and fog day at three sites in the Namib (logger data only).*

	Swartbank	Klipneus	Gobabeb
Record Days	312	305	239
Average fog water per record day (ml)	774	1074	104
Fog Days recorded	101	99	49
Average fog water per fog event (ml)	2390	3308	508
Fog Days per year (extrapolated)	118	118	75



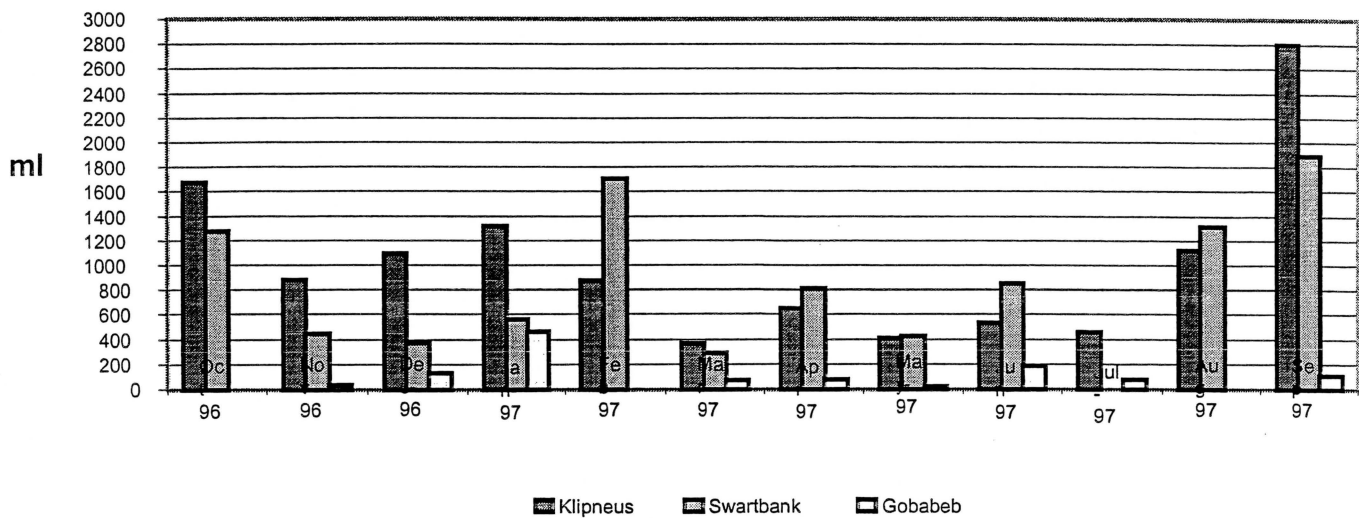

Fig 3.3: Daily average of fog volume ( $ml.m^{-2} day^{-1}$ ) recorded by data logger at different sites during different months of one year

The same number of fog days occurred at Swartbank and Klipneus, but at Klipneus the average quantity recorded was higher. The average relative quantities collected per fog event and per record day were similar, being 27.8% and 27.9% less at Swartbank than the respective quantities at Klipneus. The data logger from the SFC at Gobabeb recorded much less fog than at any other site. Despite this site's distance from the sea, some 75 days per year were foggy, but the average quantity per fog event was only 15,4% of the quantity at Klipneus.

The maximum quantity of fog collected at the three sites followed the same pattern as the average, being highest at Klipneus and lowest at Gobabeb (Table 3.2), as was the season during which the maximum fog events occurred.

At Klipneus, 14.67 litres was collected during one fog event on August 26, 1997, with an hourly peak of 4.31 litres at 17H00. At Swartbank, 11.35 litres was recorded on August 17, 1997 and 3.34 litres at 20H00. However, the maximum amount per day of 3.03 litres at Gobabeb occurred on January 1, 1997 with a peak at 04H00.

Table 3.2: Absolute Maximum fog events at Swartbank, Klipneus and Gobabeb.

	Swartbank	Klipneus	Gobabeb
Max per day (ml)	11350	14658	3030
Max per hour (ml)	3340	4310	1410
Date / Time	17. Aug 97 (20:00h)	26. Aug 97 (17:00h)	1. Jan 97 (4:00h)

Wet fog normally occurs during the night, such as the maximum at Gobabeb. Wet fog during late afternoon and evening, like the maximums at Swartbank and Klipneus, are not that common. However, during late winter to early summer (July-September), some wet fogs occur during the afternoon and last until the next morning.

### Seasonality

Apart from these afternoon fog events, there are usually no changes in the time of fog occurrence. Therefore seasonality is characterised more by the average amount of fog collected than by the time the fog occurs. The amount of fog collected is also more important for this survey, which aims to examine the usefulness of such a water supply system in the study area.

Fig.3.4 shows that Klipneus has a distinct seasonality in the collected quantity of fog water. The wet fog season (September-March) is followed by the less foggy season (March-May). Fog increases again during the period after June. This ensures a reasonably steady fog water supply during the whole year. The scattering of fog water collected, recorded by data logger, is comparable between Klipneus and Swartbank as shown in Fig.3.4. However, the recorded seasonal course of water collected at Swartbank is a bit less than at Klipneus.

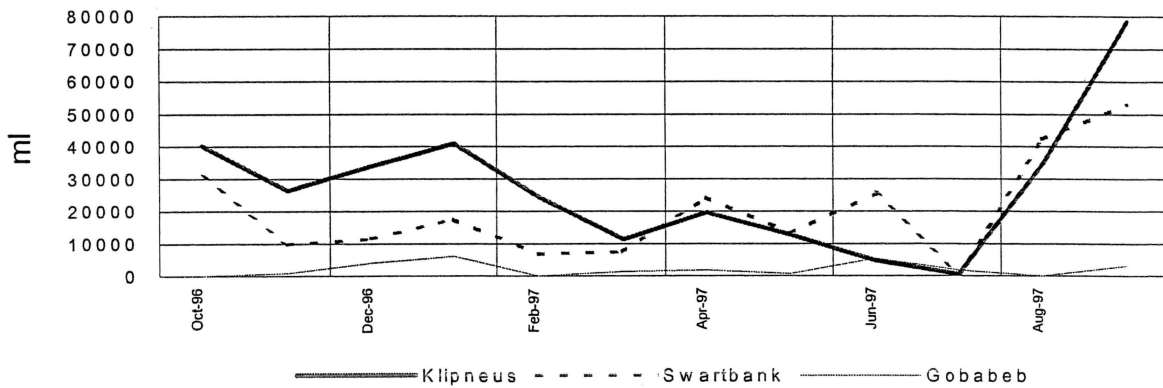

Fig.3.4: Total volume( $ml.m^{-2}$ ) of collected fog per month at different sites during one year.

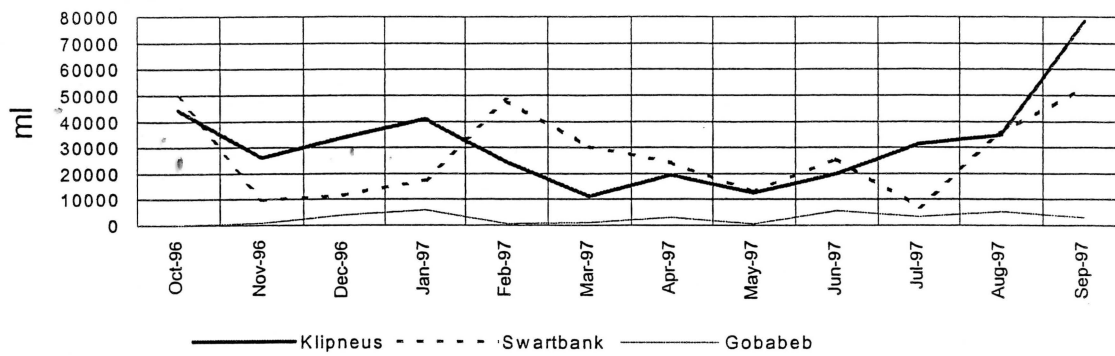

Fig.3.5: Data logger total volume ( $ml.m^{-2}$ ) per month corrected with manual data during non-recorded times.

When comparing Fig.3.4 with Fig.3.5, where the data logger gaps are corrected with manual data, it can be seen that the average amount of fog collected per month at Klipneus is much more balanced than when only logger data are used. Thus the monthly trends at Swartbank are more distinct and fairly similar to those at Klipneus.

Table 3.3: Total quantity of fog water ( $l.m^{-2}$ ) collected by SFC at three sites during the course of this study and extrapolated to one year.

Total Volume (litres)	Swartbank	Klipneus	Gobabeb
All record days	241.37	327.53	24.872
Per annum	324.06	377.93	33.582

As shown in Table 3.3, the difference of the total volume of collected fog per year between Swartbank and Klipneus is only 14,25% in comparison to the 26,3% recorded only by data logger data. The distinct change from the foggy season to the less foggy season in autumn is influenced by the beginning of the east, or berg wind season. This annual climatic phenomenon, with its dry, high-speed winds from the escarpment, reduces the instances of fog. If this predictable fluctuation is taken into consideration, it may be possible to plan a fog water supply for the whole year.

### Influence of Wind at Gobabeb

Further studies of the influence of the wind on the amount of fog collected were only possible at Gobabeb. As mentioned above, the anemometer at Swartbank broke and we lost the wind direction data. The First Order Weather Station at Gobabeb provided a better opportunity to obtain more reliable wind results than the questionable anemometer at the fog screen (at Klipneus).

The wind data from Klipneus showed that the fog reaches the screen from nearly all directions, with a slight prominence towards the NE wind sector. It is easier to interpret these data when comparing them to Gobabeb and Vogelfederberg (see below and also Section 2). The two sites are not completely comparable however, because of their different topographic conditions and consequently different local wind regimes. It is only possible to work out verified wind directions for fog at Gobabeb. The local conditions at the other sites should be surveyed in more detail.

The wind directions during fog events at Gobabeb differ greatly from the scatter at Klipneus (Table 3.4). Fog reaches the fog screen at Gobabeb from distinct northerly directions. The small number of fog events from westerly directions and the slightly increased number of fog events from southerly directions are interesting to note.

Table 3.4: Number of fog events with winds from various directions at Gobabeb and Klipneus.

Wind Direction	0	15	30	45	60	76	90	105	120	135	150	165
Gobabeb	18	18	12	7	4	2	5	3	4	2	0	3
Klipneus	5	22	9	4	14	18	1	17	15	7	14	14

Wind Direction	180	195	210	225	240	255	270	285	300	315	330	345
Gobabeb	1	1	3	4	3	3	1	4	1	8	14	11
Klipneus	5	0	4	8	1	16	5	15	7	4	7	0

Many fog events were transported by NW winds, the direction of the orientation of the SFC, but more fog reached the SFC at Gobabeb from NNE directions, at an oblique angle to the SFC. Just as much fog arrived from the NE at Klipneus where fog rarely came from the NNW. Relatively more fog events occurred from W and E in comparison to Gobabeb. The difference between Klipneus and Gobabeb is obvious, but it is not clear whether the reasons for this are the different conditions in the local wind regime dependent on different topographical conditions, or whether the instrumentation at Klipneus was not deployed optimally.

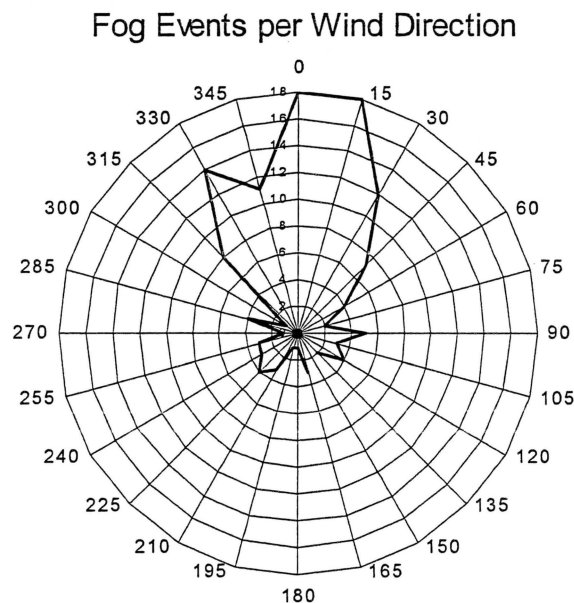

Figure 3.6: Sum of all fog events per wind direction (grouped into 15°) during Oct 96 and Sep 97 at Gobabeb

The dominant occurrence of fog at Gobabeb from northerly directions as shown in Fig.3.6 was confirmed by the spot checks we took of weather data from the last thirty years. This corroborated the results of our one-year analysis.

These results were completed by the analysis of the wetness of the fog events dependent on wind direction as shown in Fig.3.7. What is striking is the above average amount of collected fog per fog event from northerly directions. The average amount of fog collected between 330° through 0 to 30° is 192ml, two and half times more than the average per fog event from every other direction. Less fog water was collected from westerly to south westerly directions, and more from the NNE direction (see Section 2).

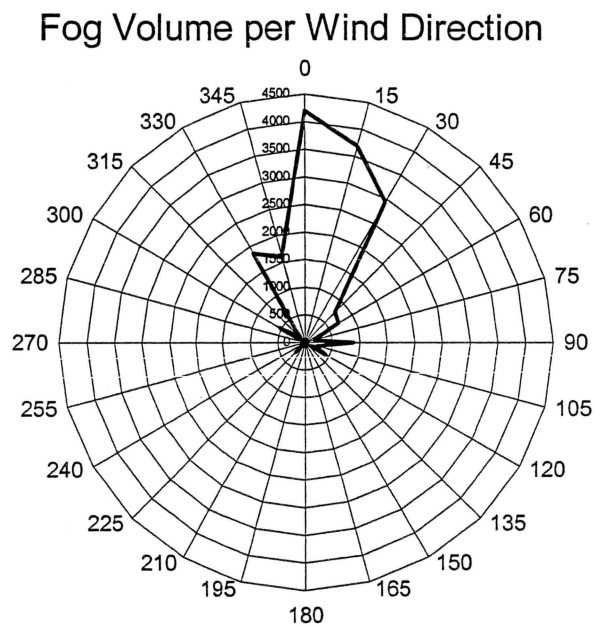

Figure 3.7: Average fog volume ( $ml.m^{-2}$ ) on an hourly base during Oct 96 – Sep 97 per wind direction (grouped into 15°) at Gobabeb

With these explicit results for Gobabeb the necessity of detailed investigations at potential fog-harvesting sites is obvious. Many conditions seem to influence the local winds and therefore the success of the SFCs. This is an important consideration, especially with regard to a water supply scheme. Again, at Gobabeb, the SFCs were oriented in a NW direction, which was not optimal. The use of a bi-directional SFC (BSFC) would present an objective record and would enable a more accurate determination of the wind characteristics that accompany fog (Appendix 3).

### Rooibank

Another SFC with data logger was situated at Rooibank but only October and November 1996 was recorded. This site is the closest one of our study areas to the sea, but the amount of fog recorded was less than at Klipneus or Swartbank. Fog only occurred at Rooibank when heavy fog was measured at Klipneus or Swartbank as shown in Fig.3.8.

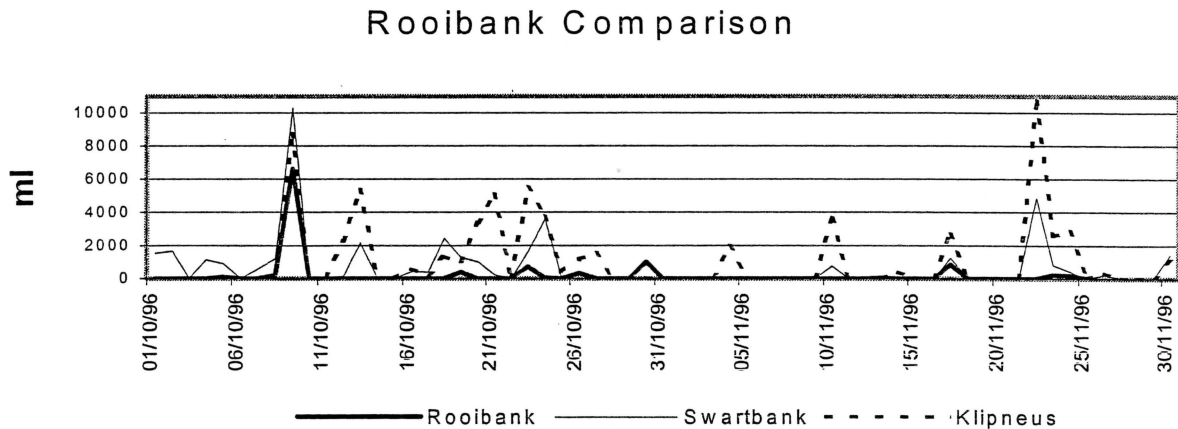

Figure 3.8: The total volume of fog ( $ml.m^{-2}$ ) recorded at Rooibank during October and November 1996 in comparison to Klipneus and Swartbank.

### Studies at Different Weather Stations

Additional SFCs were installed at the weather stations at Kleinberg, Vogelfederberg and Ganab to get more information on the occurrence of fog. The data from these weather stations give us the opportunity to link the data from SFCs with reliable weather data.

The three weather stations are situated in different areas. Kleinberg is the closest to the sea. Vogelfederberg is further inland, more or less the same distance as Gobabeb from the sea. Ganab is further inland, where fog occurs only occasionally. All three stations are situated on the gravel plains, with Ganab being in the vicinity of inseibergs, whereas Kleinberg and Vogelfederberg are situated in the open.

Data on the occurrence of fog at different sites with reliable wind data further the understanding of fog in the Central Namib Desert. Understanding the interaction between wind and fog becomes more and more important with regard to the position of the SFCs and the potential Water Supply Scheme. With the additional data from Kleinberg, Vogelfederberg and Ganab, it was possible to form an idea about the wind regime influencing the fog in the Central Namib Desert. However, the weather stations were only equipped with SFCs from March 97 onwards, so our survey on the regional fog wind regime is not comprehensive. It does suffice to give an idea of

the possible interactions and to serve as a stimulus for further studies on fog in the Namib Desert.

When examining all sites where we had measured fog during 1997 and comparing them to Klipneus as the standard, a general pattern emerges (Table 3.5). The quantity of fog water collected decreases from the coast inland. The wettest site of all was situated between Wlotzka's Baken and Henties Bay in the midst of the extensive *Teloschistes* lichen fields. An SFC oriented SW yielded more water than one oriented NW, probably reflecting the SW origin of advective (coastal) fog. Some distance inland, the fog wetness declines, but increases again at a distance of between 30-60 km inland. Swartbank may be wetter than our results reflect, as indicated by the manual data obtained from the mountain top.

Table 3.5: Comparison of various sites to Klipneus, indicating the number of days that records were made at both sites and the relative quantity of fog water (%) collected.

	km from coast	Period	Overlap days	Quantity at site (ml.m <sup>-2</sup> )	Quantity at Klipneus (ml.m <sup>-2</sup> )	% of Klipneus
Wlotzka's SW	10	Aug	19	1492	894	167%
Wlotzka's NW	10	Aug	19	1322	894	148%
Rooibank	18	Oct-Dec	49	217	861	25%
Kleinberg	31	Mar-May	73	638	354	180%
Swartbank	37	Oct-Sep	213	849	1178	72%
Vfb	60	Mar-Dec	177	514	1067	48%
Gobabeb	56	Mar-Dec	136	103	527	19%
Ganab	120	Mar-Dec	82	41	420	10%

## Conclusions and Recommendations

The average yield of 1 litre of fog per m<sup>2</sup> of collector is sufficient for the construction of a fog water scheme, especially given the urgent needs of alternative water sources and the modest quantities required by the rural Topnaar community (see Section 4). In our current study we may have substantially underestimated the quantity of water that is available, because the SFCs were oriented obliquely towards the dominant fog wind direction. SFCs were designed for a highly structured topography, such as the west coast of South America, where the wind directions are more easily determined by reckoning than is the case in the Namib Desert. We suggest the use of a bi-directional fog collector, the BSFC (Cereceda *et al.*, 1996; Appendix 3) that can be standardised against the optimal direction of a fixed SFC. When the BSFC is deployed with a weather station, it will provide accurate information on the direction of fog winds and will enable the correct selection of an optimal orientation for the large collectors of a fog water supply scheme.

Much of the area of the Central Namib between 30-60 km inland receives sufficient fog. Tops of hills are better than depressions, due to the origin of the fog as cloud. Thus, hilltops should be selected near potential sites of fog water use when prospecting for new sites. Ecological indicators are lichens (on the west side of stones, due to the abrasive effect of dry, stormy east winds) and fog plants, such as *Arthroerua* (Loris, 1990). The occurrence of these ecological indicators within 10 km of the coast, as well as several direct measurements at these places, indicates that the coast has good potential.

Given that throughout the study area fog does occur throughout the year, albeit at different frequencies and wetness (see also Lancaster *et al.*, 1984; Afrikaner, 1998; section 2), it is a good potential water source that is well-suited for the small-scale user, such as individual households or small settlements.

Besides the Topnaar settlements on which our project concentrates, other potential users of fog water could be isolated settlements along the Namibian Coast, household owners in coastal towns (e.g. for watering vegetables; Coetzee & Mulder, pers.comm.), and maybe even the bulk water scheme. A study area near Wlotzka's Baken was the wettest of all sites that we examined. This site is situated next to the Omdel Aquifer Water Scheme of Namwater and it may be possible to integrate fog water into the bulk water supply system of the West Coast.



## Section 4: Topnaar Water Needs

### Introduction

The Topnaar, or #Aoni, is a Nama-speaking tribe of originally nomadic pastoralists with a long history in the Namib Desert (Dentlinger, 1983). Besides keeping livestock (goats, cattle, and donkeys for transport), they traditionally harvest an endemic cucurbit fruit, the !Nara (*Aconthosicyos horridus*). Attempts have been made to garden on a small scale, but the water is too salty and too scarce in many settlements to allow this. In fact, the rural Topnaar community living along the lower Kuiseb river valley is very susceptible to water shortages, especially because the flooding of the Kuiseb is being reduced by dams, while water extraction for towns and mines is lowering the groundwater level (Dausab *et al.*, 1994, Jacobson *et al.*, 1995).

We conducted a pilot study of the potential of fog harvesting along the lower Kuiseb. A number of Standard Fog Collectors were erected at various locations downriver of Gobabeb in order to measure the frequency of fog events and the amount of water collected. If data collected show that the yields are sufficient, fog water could provide the Kuiseb residents with a supplementary water source to the existing supply from boreholes and wells. This would not only supply the people with fresh water, but it would also reduce the current pressure on receding groundwater resources.

To assist with the planning of a fog water supply system, it was necessary to assess the needs of people and livestock during the whole year including the increased water consumption during the holidays. For this reason we carried out a water use survey during winter (July) and summer (December) at those Topnaar settlements along the lower Kuiseb where the fog screens are located, namely, Soutrivier, Klipneus, and Swartbank. These villages are known to have a shortage of water and are seeking alternative sources (e.g. Botelle & Kowalski, 1995; Afrikaner, 1998).

Due to time constraints, it was not possible for us to interview every household in each settlement and for this reason we only interviewed the permanent residents. However, we obtained figures for the number of households in each settlement. It is difficult to derive precise figures for human and livestock water consumption. The number of inhabitants in each settlement is not constant and can vary from time to time on a seasonal and weekly basis. This influences the water consumption. Our figures are only approximate and should therefore be treated with caution. Nevertheless, they provide a guideline that should facilitate the planning of fog water supply scheme.

Rural communities throughout Namibia are currently planning to gain or improve self-sufficiency in terms of accessing and managing water sources and associated infrastructure. For instance, this is the goal of the Cost-Recovery Programme of WASP (Water Supply and Sanitation Sector Policy) of the Ministry of Agriculture, Water and Rural Development (MAWRD, 1997). This makes provision for the creation and functioning of local Water Committees composed of community members. These committees will eventually be charged with maintaining the rural water supply infrastructure and will assume legal ownership of it. In a 5-year transition period, beginning in August 1998, the government is planning to train water point managers and to implement financially sound systems. Communities will begin to handle their own operation and maintenance activities until they resume full responsibility for the operation, maintenance and replacement of equipment in September 2003.

The current investigation and future plans for water use by the Topnaars thus need to be seen in the light of this National Policy. We focus on the question of the water needs in order to address the important question of whether and how this can be met by fog.

## **Methods**

Information was gathered through interviews with water users at Soutrivier, Klipneus and Swartbank. A questionnaire (Appendix 6) was prepared beforehand. All interviews were conducted in Nama and Afrikaans. The households to be visited were not selected before arrival at the settlements. We aimed to interview permanent residents at each settlement. A household is defined as all the people, animals, and gardens whose water requirements are managed together.

Most people that we interviewed were unable to give us accurate figures and it was therefore necessary for us to carry out our own observations. At most of the households, the exact volume of containers used to collect water is not known since none of them is graduated, but we estimated their volumes and multiplied this by the number of times they were filled.

Figures for livestock water consumption are also approximate. We measured these by filling a graduated bucket with water and observing how much water one animal drank. We did this for cattle, goats and donkeys. These figures are not absolute since water consumption depends on many factors such as time of the year, distance walked and the last time watered.

Much still remains unanswered about the water usage pattern in the lower Kuiseb. This can be attributed to the fact that the time allocated for information sampling was limited and only three settlements were investigated. Thus it should be kept in mind that the data on water consumption are based on estimations made during short time spans.

## Current Water Supply

At Soutrivier water is supplied by means of a borehole fitted with a diesel pump. The greatest problems are when the machine breaks down or when the village runs out of diesel. Servicing and diesel are provided by the Government and cannot always be made available immediately they are required. However, when the Soutrivier residents face crucial times they obtain water from Gobabeb, situated 5 km away.

The water supply at Klipneus is sporadic and people constantly keep a store of water in containers at home as an emergency reserve. Currently they obtain water from a wind pump. The wind pump is maintained by the Government. Sometimes, when there is no wind, or the wind pump requires repair, the people resort to using a hand-dug well. However, brief annual river floods destroy the well and it has to be redug when the floods subside. This is becoming increasingly more difficult with the receding groundwater level.

Swartbank faces the most difficult situation, because their only water sources are hand-dug wells. Their water consumption depends on the amount of water that is in the well. During times with less water the people adjust their water consumption and dig the well deeper. When this is no longer possible, they fetch water with donkey carts from the 20km distant Utuseb school, which is connected to the Walvis Bay municipal water supply. The increased water requirements during holidays are a problem for Swartbank.

## Water Requirements

The people use water for drinking, cooking, laundry and washing. Furthermore, as pastoralists, they keep cattle, goats, donkeys, dogs and poultry that all require water. The current situation is not conducive to keeping gardens, partly because of the brackish water and partly because of the water shortage.

The village populations fluctuate (Table 4.1). Residents are occasionally joined by persons with jobs in town and school children, who spend 10-25% of their time at the villages. People use between 11% and 68% of the total water consumed, and most goes to domestic animals, with cattle requiring about half of the water (Table 2). The consumption fluctuates least at Klipneus (47%), and most strongly at Soutrivier (137%). The total volume of water consumption is highest at Swartbank, where the need for a scheme to supplement the hand-dug wells and donkey-drawn water carts is highest. The water requirements could be halved by excluding cattle.

Our survey compares well to that of Dausab *et al.* (1994), who found that the total water consumption in three Topnaar settlements ranged from 1.6m<sup>3</sup> (Soutrivier; comparable to our maximum estimate at that settlement) to 2.1m<sup>3</sup> at Homeb, located 20km upriver (east) of Gobabeb.

Table 4.1: Daily water consumption (litres) at three Topnaar village based on the populations and the individual needs, which is the amount one person or one animal requires per day.

Village		Swartbank		Klipneus		Soutrivier	
Consumer	litres/Individual	Population	Consume (litres)	Population	Consume (litres)	Population	Consume (litres)
People	22-30	15-42	330-1260	6-13	132-390	14-37	308-1110
Goats	2-4	96	192-384	50	100-200	53	106-212
Donkeys	16-18	44	704-792	20	320-360	16	256-288
Cattle	40-50	26	1040-1300	16	640-800	0	0
Dogs	2-3	6	12-18	7	14-21	10	20-30
Chickens	0.1	34	3	30	3	20	2
<b>TOTAL</b>			<b>2281-3757</b>		<b>1209-1774</b>		<b>692-1642</b>

### Attitude towards Fog as a Water Source

All in all the people in the various settlements are conservative in their attitudes towards water sources regardless of their problems. However, in our interviews, we gained the impression that many people do believe that the fog water harvesting system would be good because it is a simple technique and appears to be easier to service than diesel or wind pumps. The fog collecting system is seen as a less alien system because it operates without an engine. However, they stress that it will not be the solution because of the few fog events per year.

With their current problems, they will only be convinced of the usefulness of this technique when they see that it can supply them with sufficient good water. It is possible that the good quality of the fogwater could be an incentive to accept the fog collecting system, because the water in the settlements is often salty or brackish. Despite this wait-and-see attitude, they did express their interest in fog water and said that they would do their best to maintain a fog harvesting scheme if the system were implemented at their settlement.

### Conclusion and Recommendations

From our study we concluded that the water usage at the settlements in the lower Kuiseb is negligible when compared to that of their neighbours, the commercial farmers living in the Kuiseb Catchment, coastal towns and the mine (Dausab *et al.*, 1994). Water consumption within the settlements fluctuates with season and holidays. The patterns of water use within this community are however still somewhat unclear and therefore further research will need to be done to determine precisely how the Topnaars use their water. Fog water could turn out to be a valuable supplementary water source to help alleviate the shortage along the west coast. It is very important that the water consumers adopt the idea that fog is a resource that they can use sustainably. Water committees should be implemented at each settlement. This is an objective of the Government and would promote sustainable resource use (MAWRD, 1997).

Although the people living along the lower Kuiseb River are in need of alternative water sources, they seem to have accepted their daily struggle with the existing system as a way of life following years of Government dependency. They walk long distances to hand-dug wells that require much maintenance, while they wait patiently for a Government technician to arrive to fix a pump. On the other hand, they have expressed interest in a reliable system that they can maintain themselves with little effort. However, they currently have limited funding and do not intend to invest this towards a new water scheme, a service always provided by Government in the past. The means to afford to run the fog harvesting technology would need to be developed through a lengthy participatory process parallel to and integrated with that of the Department of Water Affairs which is focused on fostering self-responsibility for the management of this resource.

Given a more reliable source of water, the Topnaars could diversify their activities, for instance to include gardens or to attract tourists. This should improve their living standards. On the other hand, people indicated that if they obtained more water, they would keep more goats. This could increase the impact that these animals would have on the environment. However, the need for careful management of fog water may mitigate this change. Integrated water and range management is also an objective of the Department of Water Affairs and the Department of Rural Water Supply (MAWRD, 1997)

## Section 5: Designing a Fog-Water Supply System

### Introduction

The most important immediate aim of Part 1 of the NAMFOG project was to recommend whether, where, and how fog can serve as a source of potable water to the Topnaar community. This recommendation should serve to introduce the technology into Namibia, to adapt it to local conditions, and to plan the steps that are to follow the current evaluation.

The main factors that affect the design of a fog water supply system are the amount of fog and its distribution over time, the water needs and management of its consumption, the storage capacity for water, and the economic considerations. This section endeavours to explore the role of these factors and to design a pilot fog water supply system.

Based on the discussion in sections 3 & 4, we use Klipneus as an example for the current calculations of a fog water supply scheme. These can be adapted accordingly for other places as required. This choice was based on several factors, primarily that the people require water supplementation at Klipneus (as they do at several other Topnaar villages). The settlement is small, containing three households with 13 inhabitants of which 7 commute and are not permanently present in the village. The situation is thus not complex and it should be relatively easy to manage fog water in such a small settlement. Klipneus is the home of the family of Alois and Hermina !Narib, who have already become involved in this project in terms of data gathering as well as information dissemination and are interested in helping to continue the project. The residents of Klipneus are communal farmers of goats, donkeys, chickens and cattle, and seasonal harvesters and processors of !Nara fruit. Klipneus can thus serve as an example of how this technology can be applied on the small scale in western Namibia.

For the current purposes, the data on the frequency and water content of fog that were obtained from the NW-oriented SFC between October 1996 and September 1997 on the top ridge of Klipneus, situated about 2 km from the village, served as a basis for the calculations of water supply. When the data logger was not operational, manual data were substituted. Water consumption is analysed in terms of the amount required relative to the supply. The storage capacity of the tank affects the proportion of fog water that can be retained and is thus available for managed consumption. It also affects the duration that water is available.

The economic considerations that are described here have three components, namely, the construction cost of a fog water supply and storage system in terms of materials and manpower, the maintenance costs, and how these relate to the socio-economic background of the water users. This will serve as a guideline for estimating the costs of the project to develop and support a pilot scheme.

## Water availability

The Klipneus SFC yielded 1041 ml/m<sup>2</sup>/day on a total of 105 fog days in 356 study days (this differs slightly from the data presented in Section 3, because the present data sets include periods when manual data were substituted for missing logger data). The rate at which fog appeared varied during the study period (Fig.5.1) and can be divided into three periods (Table 5.1) based on the period of “water accumulation” and “water deficit” as depicted in Fig. 5.2. The initial period from 8 October 1996 to 9 January 1997 had numerous small fog events and 10 wet events with >5 litres fog/event. The frequency of fog decreased in the 6 months from mid-January to mid-July and then increased to a maximum in the final two months of the study period.

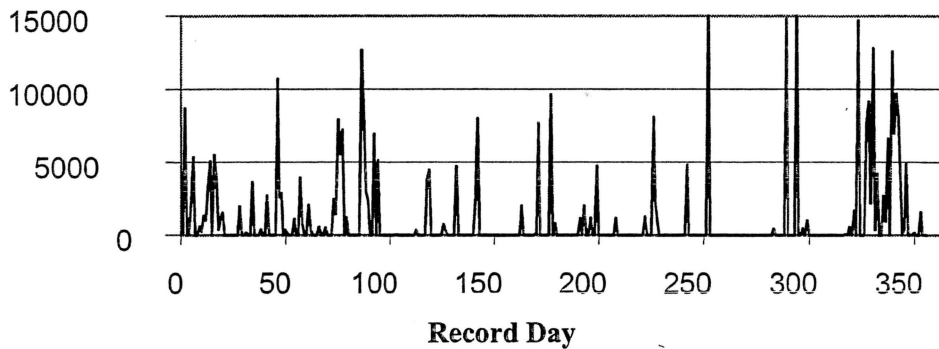

Figure 5.1: Daily records of fog water collected at Klipneus.

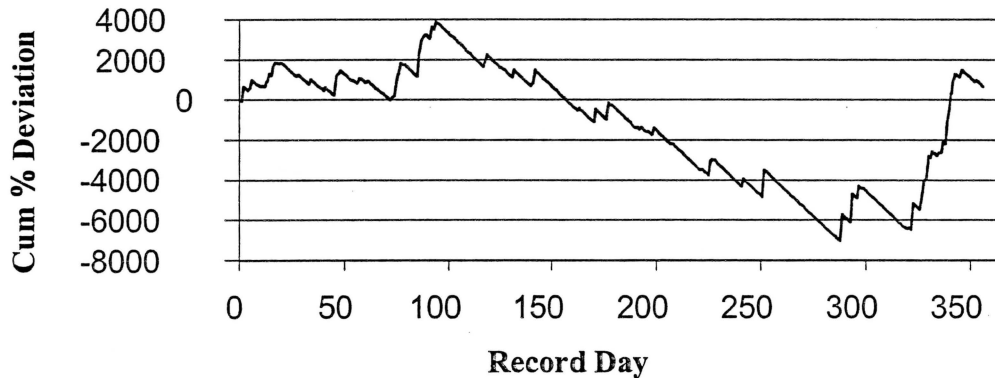

Figure 5.2: Cumulative percent deviation relative to the average of fog water (zero line) collected at Klipneus. The graph increases whenever the fog water exceeds the mean and decreases when it is below the mean. Long periods without fog cause a decline.

Table 5.1: Summary of fog water quantity and frequency of fog for three different time periods at Klipneus. The total was derived from raw data of the whole year.

Period	Average fog/day (ml/m <sup>2</sup> )	Period (days)	Number fog days	Per cent Fog days
8Oct-9Jan	1472	94	45	47.9
10Jan-22Jul	453	194	29	14.9
23Jul-28Sep	2122	68	31	45.6
Total	1041	356	105	29.5

A water scheme needs to take the variability of water availability into account, namely the accumulation of water (increase above average, Fig. 5.2) during the second half of the year, and the net deficit of water (decrease below average, Fig. 5.2) during the first half of the year when the rate of fog water supply is only one-quarter that during the second half of the year.

### Water consumption

The amount of water consumed relative to the amount that is available from fog influences how often the storage tank runs empty. The amount of fog water collected at Klipneus during the study period was used in calculations that summed the water that remains in a storage tank in multiples of the annual average (~ litres, if the collector comprised one SFC of 1 m<sup>2</sup>). The three examples shown in Fig. 5.3 indicate how sensitive the system is of running the tank empty or sustaining the supply if water is used at rates equal to or more than the annual average supply (of 1.041 liters/m<sup>2</sup>/day; based on a NW orientation of fog screens).

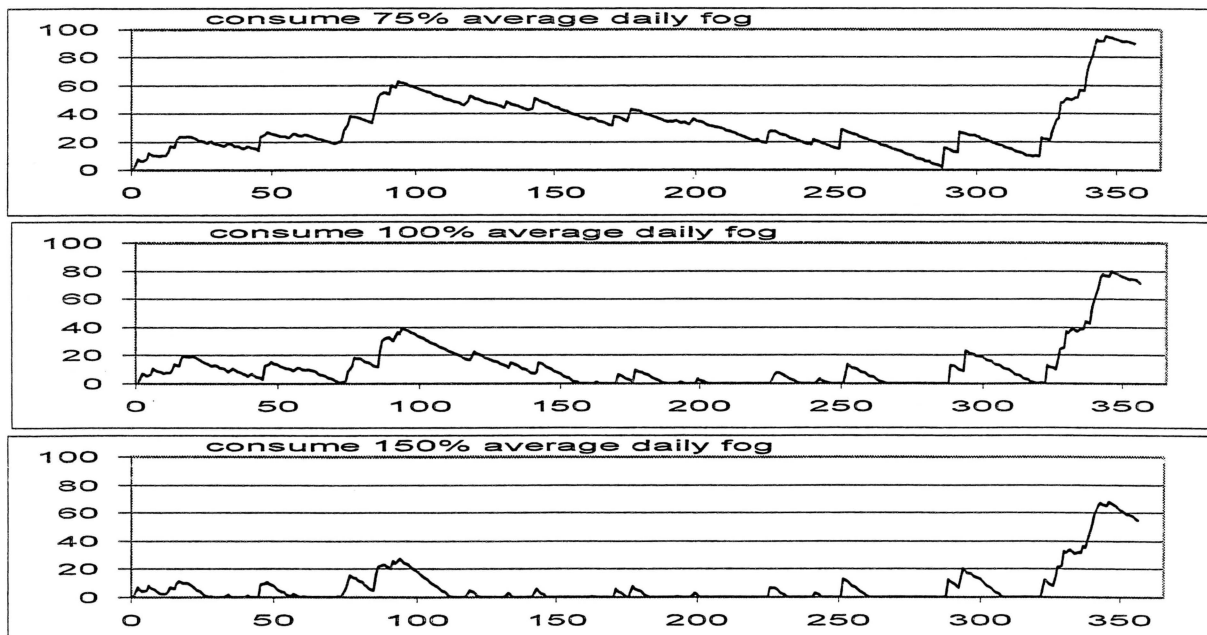

Figure 5.3: Quantity of stored water in multiples of the average daily supply depending on the rate of consumption, varying from 75% to 150% of the average daily supply.



The overall relationship of consumption relative to supply is shown in Fig. 5.4. This indicates that there is a threshold relative consumption of between 75% and 80% of the daily fog water supply, above which the tank tends to run dry. While the tank would never run dry if the rate of consumption was 75% of the rate of supply, it would be empty for 29% of the time if average annual consumption equals average annual supply. This is because consumption does not vary according to the fluctuations of the supply.

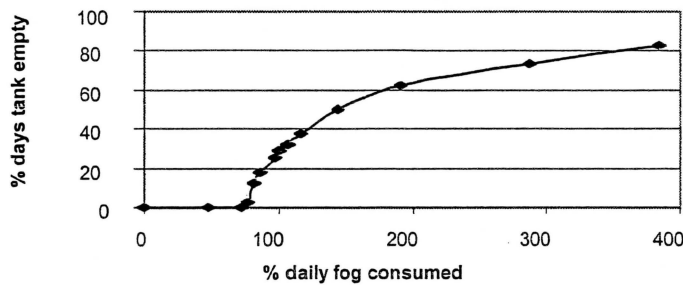

Figure 5.4: Number of days per year that the tank is empty depending on the rate of water consumption relative to the average daily supply.

From this we conclude that if fog water is to be a sustainable supply, its consumption needs to be managed very carefully and the daily consumption kept at about 75% of the average daily supply, i.e. for every square meter of fog-collecting screen, no more than 750 ml of water may be consumed per day. By comparison, the Department of Water Affairs works with a consumption figure of 90% of the sustainable yield for other kinds of water systems. Our calculations were made for when the tank has an “unlimited” capacity to store water, and the conclusion may need to be modified according to the storage capacity.

## Storage Capacity

One square meter of fog-collecting screen can collect up to 15 litres of water per day, i.e. 15 times the annual daily average, while there can also be long periods without fog (maximum duration of 17 days) when the consumers would depend on the previously stored water or need to use alternative sources.

The following calculation is based on quantities relative to the average daily supply (1041 ml/m<sup>2</sup>/day ~ 1 litre). For simplicity in this section we assume that:

- the collector is one SFC of 1 m<sup>2</sup>
- the consumption is 750 ml per day
- the storage containers to be compared range from 3 litres to 60 litres and can thus hold the fog water collected for 3 days to 2 months.

How the storage capacity affects the quantity of water available at any given moment and how often the tank is empty can be seen in the three examples (Fig. 5.5).

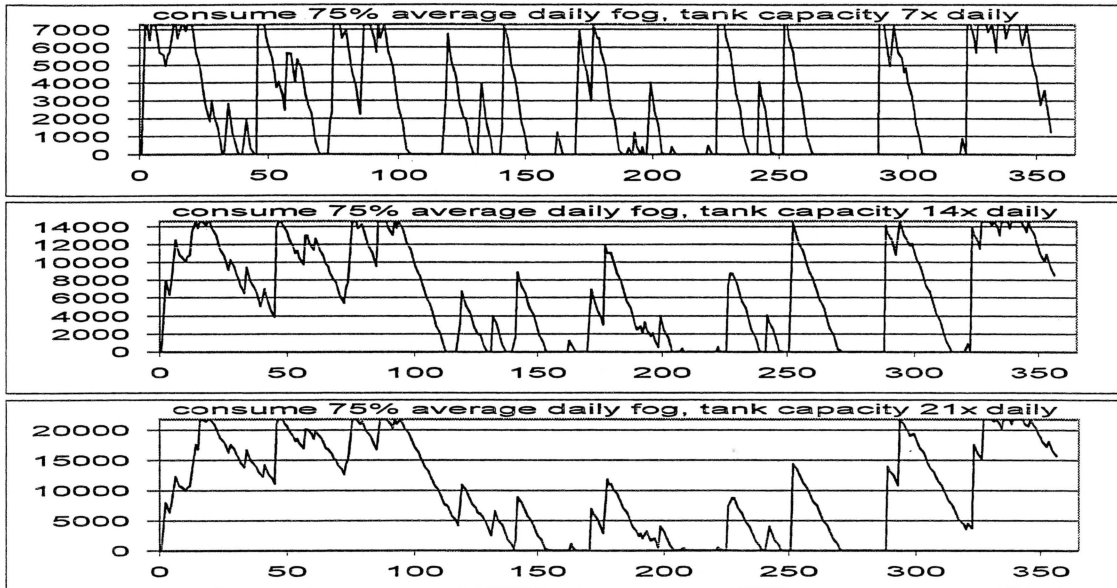

Figure 5.5: Quantity of stored water (litres) in tanks with capacities of 7, 14 and 21 times the daily fog water supply.

The storage capacity affects the number of total days per year that the tank would be empty (Fig.5.6). This decreases from 176 days for a 3-litre container, to 2 days for a 60-litre container. Between containers of 20-60 litres, the decline in the number of days is steady and approximately linear. At 25 litres, the tank would be empty for 52 days, or, on average, for one day per week, while at 50 litres, it would be no more than one day per month.

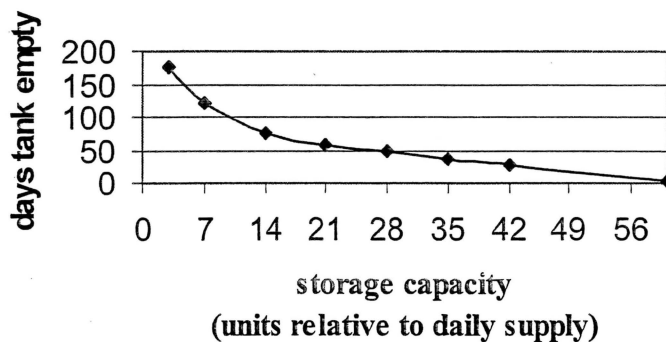

Figure 5.6: Number of days that the water storage tank would be empty depending on the size of the tank (in the above example, size is in litres).

The storage capacity also affects the proportion of the collected water that can be retained in the available storage container (Fig. 5.7). A container of 15 litres retains over 95% of the collected fog water, while this amount drops considerably below 10 litres. The excess water that cannot be retained would overflow and would need to be used immediately (e.g. providing water to livestock or a garden), or would be wasted.

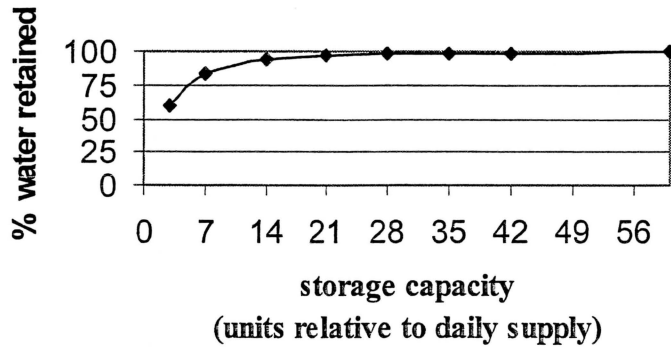

Figure 5.7: Proportion of the collected water that is retained in the storage tank depending on the size of the tank (in the current example, size is in litres).

This indicates that for the fog water collection pattern documented at Klipneus during 1996/1997, the storage capacity should be at least 21 times the average daily supply if the reservoir should not be empty more frequently than one day per week and if >95% of the water is to be retained. The “overflow” should be devoted to a useful, but flexible, purpose such as a garden or domestic animals. A major problem could be that the days without water (Fig.5.5) and with a surplus (Fig.5.8) are not evenly distributed throughout the year. Overflowing occurs in the months of August-December, whereas the deficiency occurs between March and July.

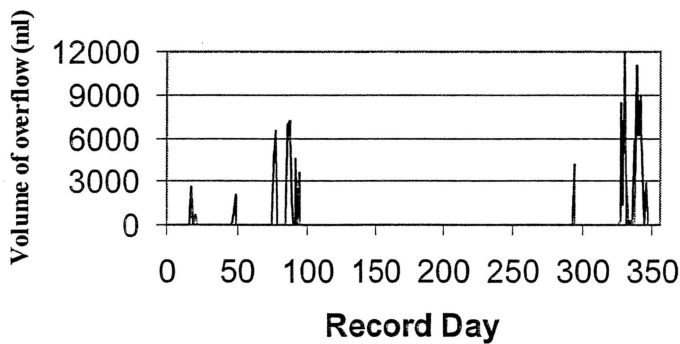

Figure 5.8: Day and volume of water overflowing a 21 litre storage tank in the above example.

### Management of Consumption

The above discussion is somewhat unrealistic, because consumption was treated as a constant. This does not conform to the changing water demand by people and animals due to seasonality in the requirements and fluctuating populations in the village.

When the water consumption rate is adjusted crudely to change depending on the supply rate, sustainability increases (Fig.5.9). If the consumption dropped to half whenever the tank was less than half full a 21-factor tank would be empty on only 4 occasions (Fig.5.9). Adjusting the consumption to the supply is obviously better than keeping it constant, but it may not be practical for the consumers. Such a crude 2-level consumption plan may, however, be possible to implement if there is an alternative water supply for the cattle at certain times, especially in the period January to July (days 106-289, 22Jan-22Jul, in Fig. 5.9). Unless consumption is even more finely tuned (beyond the sophistication of the current design), the village should have an alternative source of water during early winter to see them through the dry periods.

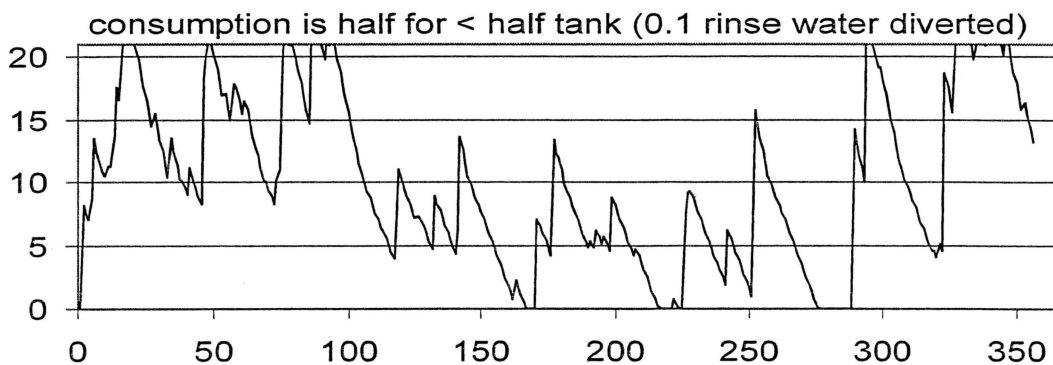

Figure 5.9: Volume of water in a 21-factor tank if the consumption drops to half-factor when the tank is over half empty and the rinse water of 0.1-factor is diverted.

Besides including or excluding the cattle, there may only be a limited capacity for the Topnaars to adjust their consumption rate to match the seasonal collection rate. This can be seen from the following data (Table 5.2) that were derived from the needs assessment (section 4).

Table 5.2: Number of water consumers and their consumption at Klipneus (requirements and consumption in litres).

Consumer	Population	Minimum requirements l/ individual /d	Maximum requirements l/ individual /d	Minimum consumption total	Maximum consumption total	Percent Consumption
People	6-13	22	30	132	390	10.9-22.0
Goats	50	2	4	100	200	8.3-11.3
Donkeys	20	16	18	320	360	26.5-20.3
Cattle	16	40	50	640	800	52.9-45.1
Dogs	7	2	3	14	21	1.2
Chickens	30	0.1	0.1	3	3	0.2
<b>TOTAL</b>				1209	1774	

Variability in consumption depends on several factors. People move in and out of Klipneus according to public and school holidays and social events. Furthermore, the requirements per individual change between winter and summer. The requirements of people never exceeds one-quarter of the total, whereas cattle account for about half the consumption.

However, the range of water consumption encompasses a relatively narrow range (1200 - 1800 litres), much less than the fourfold range of seasonal fog water supply (Table 5.1). Consumption would be considerably reduced by providing the cattle with water other than fog during the dry season, but this may not be practical and may require a major adjustment in the day-to-day operations of the pastoralists. This would, however, enable the seasonal range of water consumption to adapt to the supply pattern. The following plan assumes that there will be an alternative source of water for the cattle at certain times to ensure the sustainability of the supply for all other consumers, including the fluctuating number of people.

### Components of a fog water supply system

*Number of FCUs* – Without cattle, the present water requirements at Klipneus are 569-974 litres per day. Fog screens with a total area of 1000 m<sup>2</sup> (21 FCUs of 48 m<sup>2</sup> each) would meet these water requirements. 25 FCUs (1200 m<sup>2</sup>) would meet the minimum total requirements if cattle are included at times, and 38 screens would be necessary to cover the maximum requirements. It is suggested that initially 25 screens should be constructed, which would require a reservoir of 25m<sup>3</sup> (this would be emptied in 21 days without fog) and would fit the calculations made for Fig.5.9. This system would deliver up to 18 m<sup>3</sup> of water per day, on average 1.25 m<sup>3</sup>.

*Water processing and transport* – The Klipneus Top ridge is about 3.2 km away from the reservoir site situated in the middle of the Klipneus village. A 40-mm pipe that allows a water flow of 1.2 l/s is required. At several places, the pipe is interrupted by intermediate tanks that prevent an undue buildup of pressure. The intermediate tanks can also be used to clean the water of impurities. The very first water to pass through the system will contain the turbid brackish water that rinsed the screens. It is suggested that this initial amount of 120 litres, equivalent to 0.1 ml per m<sup>2</sup> of screen, be diverted to a rinsewater tank (capacity 600 litres, to be used for cleaning or for domestic animals) and the remainder be filtered and cleaned before storage in the reservoir.

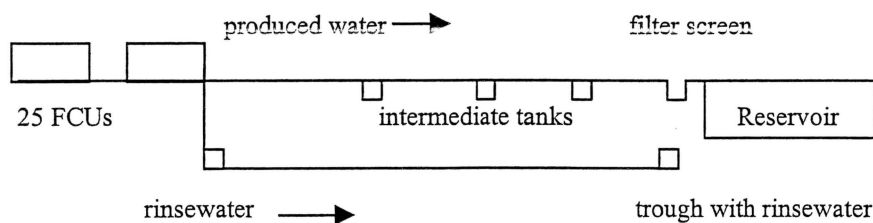

Figure 5.10: Illustration of the elements of the Klipneus water supply scheme.

*Water storage & delivery* – The reservoir should have a minimum capacity of 21 days water supply i.e. a full tank would last for 21 days at normal consumption without adding water. For the current scale, a 25m<sup>3</sup> tank would be required to replace or extend the existing 8m<sup>3</sup> tanks. Such a tank should contain water for at least 96.7% of the year if the consumption is managed.

The water delivery system can be designed to incorporate a simple management tool: the reservoir only delivers a fixed amount of water. Two 600-litre side tanks should be situated next to the main reservoir. One would be the tank that supplies the households and can also be used for domestic animals excluding cattle. The second tank would supply the cattle or other livestock. This second tank would contain the rinse water (120 litres per fog, see above) and would only be filled with a predetermined amount if the main reservoir is more than half full. It is planned that the side tank(s) be filled up once a day (the water manager opens the tap to fill up the tank(s) in the morning or evening). This quantity serves as the daily ration. This is illustrated as follows:

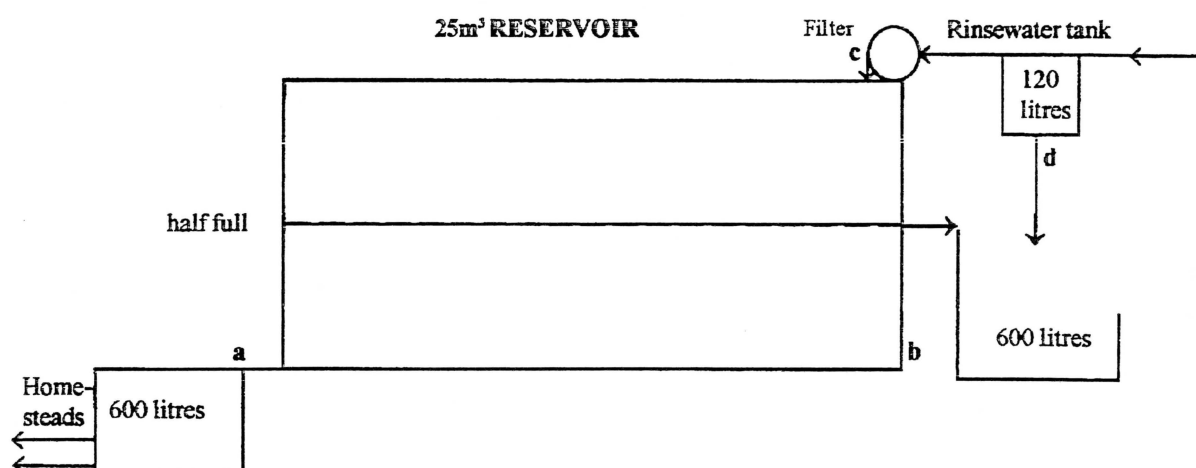

Figure 5.11: Illustration of the elements of the water storage and delivery system.

The reservoir thus has two outlets, one for the households, which can be shared between the people and their domestic animals as required and one for cattle. The latter would contain the initial 120 litres of fog water from the rinsewater tank that had rinsed the screens and could be filled up with reservoir water during times when the main reservoir was more than half full.

Although the water rationing would be managed by a person who should make a note of the activities, water gauges should also be installed at each inlet and outlet (a, b, c & d in Fig.5.11). This would assist the planning of water reallocation if and when required for the experimental water supply scheme. It would also improve the experience gained from the pilot scheme for transfer to other villages.

## Detailed Design of the Elements

*FCU* – The Conaf design of a Fog Collecting Unit (FCU) was copied (Cereceda *et al.*, 1996), except for additional supports to strengthen the structure during east wind storms. It is a screen composing a double-folded Rashel mesh with an area of  $48\text{m}^2$ , the screen being 4m high by 12m long and its base is raised about 2m above the ground. An extra pole was added in the centre of the 12m structure, and this bore cross-wires that helped to contain the billowing and stretching of the screen during strong winds (Fig. 5.12). The cost of these additional structures was 3.5% of the total cost of the hardware.

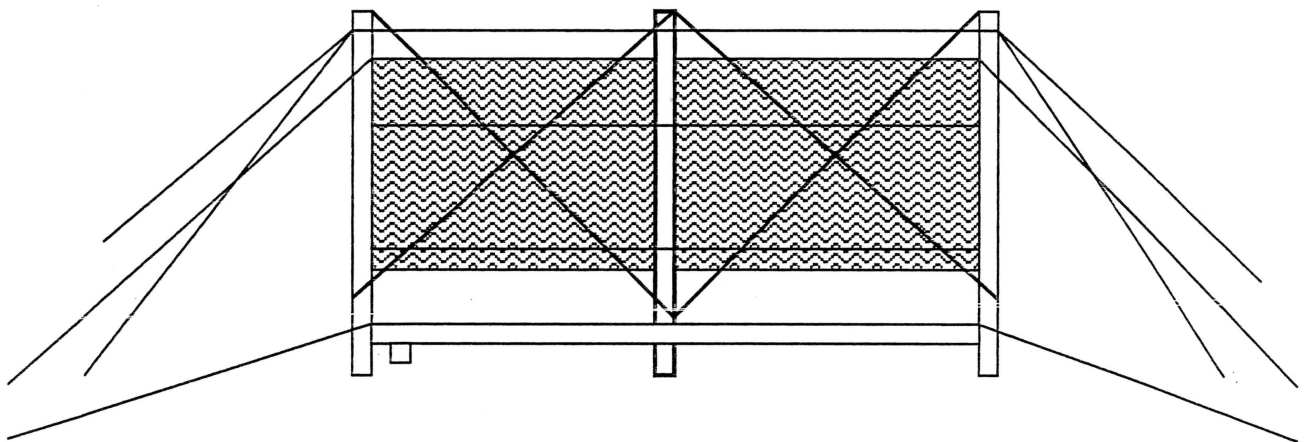

Figure 5.12: Illustration of a side view of an FCU with the added structural supports drawn in bold.

*Sedimentation tank* – Tanks are inserted along the pipe that connects the FCUs with the reservoir. These have the dual role of pressure releasers as well as sedimentation tanks. To this end, cross-walls are inserted inside, over or under which the water must pass on its path (Fig.5.13). The water flow slows down due to the width of the tank and sediments can settle. Periodically, this tank is opened and cleaned.

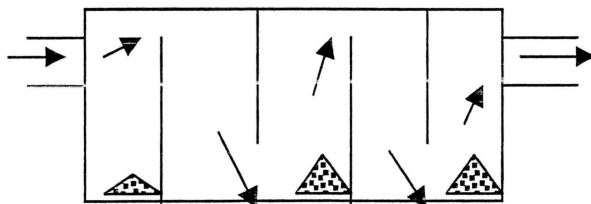

Figure 5.13: Illustration of a cross-section of a sedimentation tank, indicating the flow of water.

*Rinsewater tank* – A small tank is inserted in the pipe before the water enters the reservoir. This takes the very first water and then diverts it on to the reservoir when it is full. The rinsewater tank has a flap that acts as a valve. This swims on the water and closes against a seal so that the water bypasses this small tank when it is full (Fig.5.14).

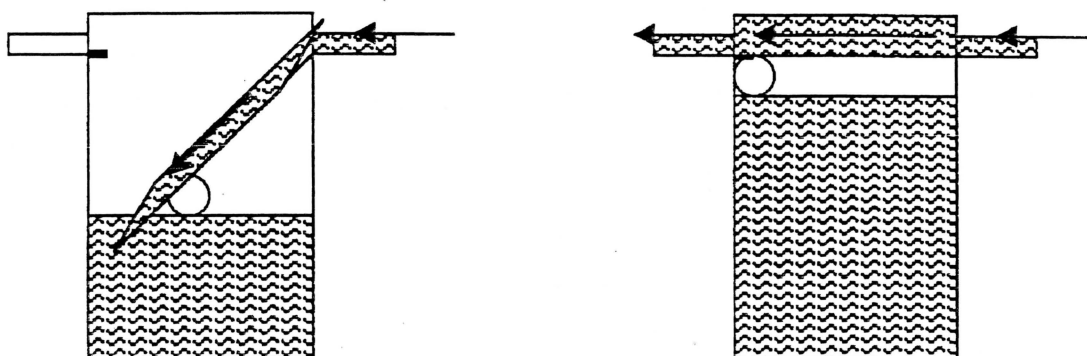

Fig.5.14: Rinsewater tank with lid and float that rises (left) to seal the valve when it is full so that the remainder of the water is diverted (right).

## Costs

The cost of water between various types of sources was compared, ranging from fog to borehole operating with diesel pump or wind pump, or hand-dug well. Costs for the elements of water supply schemes were based on our direct experience with FCUs in Namibia (Table 5.3) and for other types we used the costs that the governmental Rural Water Supply uses as a guideline (Greiner, 1967) (see Appendix 4). Added to the cost of the water supply is the cost of the infrastructure to store and distribute the water (pipes, taps, reservoirs, etc.), calculated as N\$46 407. This cost may differ depending on whether the fog water supply scheme is communal or individual, especially because the individual would have to lay own water pipes from the FCUs to the house.

Table 5.3: Estimated cost of constructing one Fog Collecting Unit (FCU) by the community. Transport costs are shared, based on the simultaneous purchase of 25 FCUs.

\* = the quoted price in Namibia during May 1998 was N\$8.12/m<sup>2</sup>.

Item	Cost N\$
Screen mesh (@ N\$10/m <sup>2</sup> for 100 m <sup>2</sup> per FCU) *	1,000
Other Hardware for FCU	1,500
Labour: 120 h	self
Transport (1/25 <sup>th</sup> of N\$3,500)	140
Total	2,640



When calculating the costs of the infrastructure of the water supply scheme, labour and maintenance (Appendix 4), it turns out that the fog water scheme with 25 FCUs would cost nearly N\$180,000 and 13,400 hours of work by members of a settlement over a 10-year period, converting to N\$31/m<sup>3</sup> and 2.3 h/m<sup>3</sup> (Table 5.4). The cost would be substantially reduced (perhaps by half) if the yield was underestimated by our wrong orientation of the SFCs during the current study, as we suspect. Fog is competitive with the wind pump in terms of cost, and requires only some half the amount of work that a hand-dug well does.

All prices shown in Table 5.4 may appear to be rather high compared to urban prices. Rural water prices are not comparable to urban prices, because of the great distances that construction teams and service technicians need to travel in rural areas to service pumps and the big investment in terms of time and labour by the users themselves. On the other hand, water consumption in rural settlements is low, much lower per capita than in urban regions. This, however, makes the costs per unit volume of water more expensive for small water supply schemes. The actual costs for the diesel and wind pumps are paid by the government as a gratis service to rural communities, although this situation may change in the near future.

*Table 5.4: Calculated total cost over 10 years of different types of water sources. Unit cost is calculated for Klipneus, which uses 1.5 m<sup>3</sup> per day, giving 547.5 m<sup>3</sup>/yr, with an incremented 5% annual increase, totalling 5,749 m<sup>3</sup> in 10 years. Costs are derived in Appendix 4.*

Type	Self-labour h	Installation & Maintenance N\$	Water Management	Total Cost N\$	Cost N\$ per m <sup>3</sup>	Time h per m <sup>3</sup>
25 FCUs communal	13,400	132,000	46,407	178,407	31.03	2.33
Diesel pump	3,650	174,336	46,407	220,743	38.40	0.63
Wind pump	3,650	116,367	46,407	162,774	28.31	0.63
Hand-dug well	31,220	11,200	0	11,200	1.95	5.43

Of all the water sources, fog has the best potential for individual households to operate their own supply system. This would increase the total costs somewhat because the water management system is not shared. Assuming that a small water management system would cost N\$10,000 (used especially for pipes and a 5 m<sup>3</sup> tank) and that one household and its domestic animals would require 5 FCUs, the construction costs would be N\$23,200. The total cost in 10 years would be about N\$36,400, or N\$31.66/m<sup>3</sup>. The possibility of households having their own water supplies increases the flexibility for the application of this technology. It may increase the potential of individual economic development within the communal setting of the settlements. FCUs would become equivalent to "estate", where the frame is the "immovable" and the mesh the "movable", similar to other parts of their homesteads. Such a system would take the onus off having to predict the future population in a settlement, which has always been variable in the Topnaar settlements. Individuals can decide for themselves, provided they can raise the money to construct their own fog water scheme. If the Topnaar community forms water committees and cooperatives that assist in this regard (e.g. reduce costs or make loans available), then this more

flexible approach may have potential. This possibility should be investigated.

Water from boreholes and wells has an inherent disadvantage compared to fog water in that the source is limited, is declining, and the water quality is often poor because it is brackish (Topnaar Community & Department of Water Affairs, pers.comm.). Fog water is not only of good quality, but it is also a sustainable resource, with no more of an environmental disturbance than a building. Given that the relative cost of fog water is equivalent to that of a wind pump, which appears to be acceptable to the Topnaar community in preference to the labour-intensive, traditional hand-dug wells, and that fog is a better water source in terms of sustainability and environmental friendliness, fog has a distinct advantage over the other sources.

## **Environmental Effects**

After fog has passed through the fog-water collecting screens, it bears less water than before (about 50% less in optimal conditions; Schemenauer & Cereceda, 1994b). As numerous desert organisms, plants and animals depend on fog water, it could be argued that this reduction of the wetness of the fog could have a negative impact on the environment. However, this appears to be negligible. The FCU screen is two metres off the ground so that the bottom portion of fog that animals and plants would utilise is unimpeded. Secondly, the sides of the fog cloud close around the relatively narrow FCU (12m wide) and the fog shadow soon becomes indistinct (Cereceda *et al.*, 1996). The FCU, and even a whole bank of FCUs, is tiny compared to other obstacles in the landscape (e.g. hills). The amount of water that it removes from the thick fog cloud stretching over hundreds of kilometres over the Namib is negligible.

Another environmental effect is created by building an artificial structure onto hilltops in an otherwise undeveloped area. The effects can be aesthetic as well as physical, both of which are of particular concern in the Namib Naukluft Park where the target Topnaar villages are located. The aesthetic effects can be minimised by using unobtrusive sites that are not visible from very far. For this reason, the Swartbankberg, an Inselberg consisting of a marble block with a top ridge that is clearly visible for 30 km east and west, is not recommended, despite its close proximity to a Topnaar settlement. Subsequent to our current measurements on the Swartbankberg, we located a site which appears to be even better in terms of fog yield, proximity to the settlement, and unobtrusiveness.

The physical impact of a fog water supply scheme involves the actual placement of the FCUs, the pipeline and a road to the site. The whole area within several kilometres of Topnaar settlements is already frequently traversed by people, livestock, donkeycarts, bicycles and cars travelling off-road, so that the organised development of a fog water supply scheme should not be a major new interference to the landscape.

## **Conclusion and Recommendations**

The occurrence of some fog throughout the year makes it possible to base a water supply scheme only on this source. The average consumption rate needs to be carefully balanced against the average supply rate. Otherwise the reservoir would frequently run empty and this water source would be seen as being unreliable. This can be avoided by designing a sufficiently large fog harvesting water scheme and then adding checks to prevent extreme fluctuations in consumption above a certain maximum. One simple management aid would be filling daily rations into a smaller tank and to separate the water used for cattle from the water used for the rest.

Fog competes well with the cost of existing systems. It is, however, labour-intensive relative to diesel and wind pumps, but much less so than for the hand-dug wells. The construction of a pilot fog water supply scheme would demonstrate the validity of our calculations besides testing the acceptability of this type of water source in the community.

## Section 6: Literature

### Namfog Publications

Eckardt, F. 1996. Fog water for people. *Namib Bulletin* 13: 6.

Henschel, J.R. 1996. Studying and using fog in the Namib Desert. In: Semenzato, R. (ed.) Evaluation of fog as a water resource. *European Commission Programme STD3 Workshop Report*.

Henschel, J.R. 1997. Fog harvesting. *Namib Bulletin* 14: 8-9.

Mtuleni, V., J.R. Henschel & M.K. Seely, 1998: Evaluation of fog-harvesting potential in Namibia. *Proceedings of the 1<sup>st</sup> International Conference on Fog and Fog Collection, Vancouver, Canada*.

Seely, M.K. & J.R. Henschel, 1998: The climatology of Namib fog. *Proceedings of the 1<sup>st</sup> International Conference on Fog and Fog Collection, Vancouver, Canada*.

Seely, M.K., J.R.Henschel & M. Robertson, 1998: The ecology of fog in Namib sand dunes. *Proceedings of the 1<sup>st</sup> International Conference on Fog and Fog Collection, Vancouver, Canada*.

### Outputs of Namfog Phase I (Evaluation)

Brochures: a) Topnaars; b) Gobabeb visitors; c) West Coast; d) Namibia

Press releases and interviews to local and international printed and TV/radio media

Presentation by Vilho Mtuleni at the ECEP meeting in Harare, Zimbabwe

Three presentations by Vilho Mtuleni and Mary Seely @ Vancouver fog conference

Video on Fog Harvesting in the Namib by Mokobo Video & Research

Scientific publications on Namib Fog

### References Cited

Afrikaner, C., 1998. The investigation of fog frequency and occurrence patterns in the Central Namib as a possible alternative source of water supply to the Topnaar Community along the Kuiseb River in the Namib Desert. *BA(hons) thesis, Department of Geography, University of Namibia*, 17 pp.

Besler, H., 1972. Klimaverhältnisse und klimageomorphologische Zonierung der zentralen Namib (Südwestafrika). *Stuttgarter Geographische Studien*, pp.209 pp.

Botelle, A., & K. Kowalski. 1995. Changing resource use in Namibia's lower Kuiseb river valley: perceptions from the Topnaar community. *Institute of Southern African Studies at the University of Lesotho and the Social Sciences Division at the University of Namibia*. Desert Research Foundation of Namibia, Windhoek, 90 pp.

Cereceda, P., A. Cruzat, J. Ossandon, & R. Schemenauer, 1996: Prospection, evaluation and construction of fog water collection systems: a new technology of simple application and large economic and social impact. *IDRC/CIID-GAFCS*, 80 pp.

- Cereceda, P. & R.S. Schemenauer, 1991. The occurrence of fog in Chile. *Journal of Applied Meteorology*. 30, 1097-1105.
- Cereceda, P., R.S. Schemenauer, & M. Suit, 1992: An alternative water supply for Chilean coastal desert villages. *Water Resources Development* 8, 53-59.
- Dausab, F., G. Francis, G. Jöhr, J. Kambatuku, M. Molapo, S.E. Shanyengana, & S. Swartz. 1994: Water usage patterns in the Kuiseb catchment area (with emphasis on sustainable use). *Occasional Report No. 1, Desert Research Foundation of Namibia*, Windhoek, Namibia, 120 pp.
- Dausab, R. & J.R. Henschel, 1997: Nara workshop of the 19<sup>th</sup> November 1997 at Lauberville. Proceedings, Desert Research Foundation of Namibia and Topnaar Community, 10 pp.
- Dentlinger, U., 1983. *Social and spatial mobility along the Kuiseb River in the Namib Desert, Namibia*. MA thesis, University of Cape Town, South Africa.
- Eckardt, F., 1996: *The distribution and origin of gypsum in the Central Namib Desert, Namibia*. PhD Thesis, University of Oxford, 320 pp.
- Goudie, A., 1972. Climate, weathering, crust formation, dunes, and fluvial features of the central Namib Desert, near Gobabeb, South West Africa. *Madoqua, Series II*. 1, 15-31.
- Greiner, F.G. (1997) Financial management of Rural Water Supply. Ministry of Agriculture, Water and Rural Development Windhoek, Namibia.
- Gurka, J.J., 1975. Distinguishing fog from stratus on satellite pictures. *Satellite Applications Information Note*. 10, 1-2.
- Gut, S. & M.K. Seely, 1988. Can satellite imagery be used to determine the distribution of fog in the Namib Desert? *Unpublished manuscript, Desert Ecological Research Unit*.
- Jackson, S.P., 1941. A note on the climate of Walvis Bay. *S.Afr. Geographical Journal*, 23, 46-53
- Jacobson, P.J., K.M. Jacobson, & M.K. Seely, 1995: *Ephemeral rivers and their catchments: sustaining people and development in western Namibia*. Desert Research Foundation of Namibia, Windhoek, 167 pp.
- Lancaster, J., N. Lancaster, & M.K. Seely, 1984. Climate of the central Namib Desert. *Madoqua*. 14, 5-61.
- Lindesay, J.A. & P.D. Tyson, 1990. Thermo-topographically induced boundary layer oscillations over the central Namib, southern Africa. *International Journal of Climatology*. 10, 63-77.
- Martin, H., 1963. A suggested theory for the origin and a brief description of some gypsum deposits of South West Africa. *Transactions of the Geological Society of South Africa*. 66, 345-351.
- MAWRD, 1993. Central Area Water Master Plan: 10 volumes. Ministry of Agriculture, Water and Rural Development, Windhoek, Namibia.
- MAWRD, 1997. The implementation of the community management and cost recovery aspects of the Water Supply and Sanitation Sector Policy (WASP). *Agenda memorandum for Cabinet, Ministry of Agriculture, Water and Rural Development*.
- Mtsheni, V., J.R. Henschel & M.K. Seely, 1998: Evaluation of fog-harvesting potential in Namibia. *Proceedings of the 1<sup>st</sup> International Conference on Fog and Fog Collection, Vancouver, Canada*.
- Nagel, J.F., 1959: Fog precipitation at Swakopmund. *Union of South Africa Newsletter* 125, 1-9.
- Nagel, J.F., 1962. Fog precipitation measurements on Africa's Southwest Coast. *South African Weather Bureau, Notas*. 11, 51-60.
- Nieman, W.A., C. Heyns & M.K. Seely, 1978: A note on precipitation at Swakopmund. *Madoqua* 11, 69-73.

- Olivier, J., 1992. Some spatial and temporal aspects of fog in the Namib. *SA Geographer* 19, 106-126.
- Olivier, J., 1995. Spatial distribution of fog in the Namib. *Journal of Arid Environments* 29, 129-138.
- Olivier, J. & P.L. Stockton, 1989: The influence of upwelling extent upon fog incidence at Lüderitz, southern Africa. *International Journal of Climatology* 9, 69-75.
- Pietruszka, R.D. & M.K. Seely, 1985: Predictability of two moisture sources in the Namib Desert. *South African Journal of Science* 81, 682-685.
- Schemenauer, R.S. & P. Cereceda, 1994a: Fog collection's role in water planning for developing countries. *Natural Resources Forum* 18, 91-100.
- Schemenauer, R.S. & P. Cereceda, 1994b: A proposed standard fog collector for use in high-elevation regions. *Journal of Applied Meteorology* 33, 1313-1322.
- Schemenauer, R.S., H. Fuenzalida, & P. Cereceda, 1988. A neglected water source: the Camanchaca of South America. *Bulletin of the American Meteorological Society*. 69, 138-147.
- Schulze, B.R., 1969. The climate of Gobabeb. In *Scientific Papers of the Namib Desert Research Station* 4, 5-12.
- Seely, M.K., 1979: Irregular fog as a water source for desert dune beetles. *Oecologia* 42, 213-227.
- Seely, M.K. & J.R. Henschel, 1998: The climatology of Namib fog. *Proceedings of the 1<sup>st</sup> International Conference on Fog and Fog Collection, Vancouver, Canada*.
- Seely, M.K., J.R. Henschel & M. Robertson, 1998: The ecology of fog in Namib sand dunes. *Proceedings of the 1<sup>st</sup> International Conference on Fog and Fog Collection, Vancouver, Canada*.
- Seely, M.K. & Stuart, P., 1976. The climate of Gobabeb, ten year summary 1962/72. *Namib Bulletin* 1, 7-9.
- Shannon, L.V., 1972. Circulation patterns and water mass movements along the West and South-West Coasts. *South African Journal of Science*. 68, 124-126.
- Shannon, L.V., M.K. Seely, & J.D. Ward, 1989. Proceedings of the Namib-Benguela interactions workshop at Gobabeb. *Foundation of Research Development, Ecosystem Programmes, Occasional Report Series*, 38 pp.
- Struthers, M.J., 1995. *Pilot fog study at Kleinsee - Progress Report: July 1995 to October 1995*. Division of Earth, Marine and Atmospheric Science and Technology, CSIR, Stellenbosch, South Africa.
- Struthers, M.J., 1997. *Water from fog study on the Cape West Coast progress report: December 1995 to May 1997*. Reprint, No. CSIR ENV/S- I 97018, Division of Water, Environment and Forestry Technology, CSIR, Stellenbosch, South Africa.
- Taljaard, J.J., 1979: Low-level atmospheric circulation over the Namib. *Newsletter of the Weather Bureau of South Africa* 361, 65-67.
- Tyson, P.D. & M.K. Seely, 1980. Local winds over the central Namib. *The South African Geographical Journal*. 62, 135-150.
- Vendrig, M., 1990 Fog occurrence and measurement in Namibia. *Unpublished manuscript* 32 pp.

# APPENDICES

## Appendix 1: Namfog Phase I Calender

- Early 1995: International fog expert, Dr. Bob Schemenauer, and representative of IDRC, Dr. Derek Webb, visit Namibia to discuss the initiation of a fog project by a Namibian institution
- January 1996: DRFN applies to the IDRC to fund an evaluation of fog harvesting in Namibia, application was granted
- May 1996: International fog expert, Prof. Pilar Cereceda, visits from Chile on behalf of the IDRC to provide advice
- June 1996: the Topnaar community assents to cooperate and to monitor fog near their villages
- July 1996: monitoring of fog water with Standard Fog Collectors begins at 10 places in the Namib Desert with the assistance of Topnaars (!Narib & Cloete)
- August 1996: DRFN staff (Mtuleni & Henschel) learn fog-harvesting concept and technology in Chile
- September 1996: DRFN staff (Henschel) learns ecosystem restoration with fog in Peru
- June-December 1997: water use and awareness assessments with the Topnaars
- December 1997: fieldwork for the current analyses stop (monitoring continues on a long-term basis)
- December 1997-April 1998: data analyses and report production (Grunkowski, Henschel, Mtuleni, Robertson, Seely, Shanyengana)
- March 1998 onwards: fieldwork at further test sites
- April-June 1998: video production
- 24-25 April 1998: construction of first big fog collector at Gobabeb
- 26 April 1998: fog information day: presentation of Phase I
- 26 April 1998: generation of visual and printed publications
- 9 May 1998: fog workshop with Topnaar community
- 12 May 1998: publication of report
- 12-14 May 1998: oral presentation of project at ECEP conference in Harare, Zimbabwe (Mtuleni)
- 26 May 1998: follow-up meeting with community
- 26-29 May 1998: construction of second big fog collector at Klipneus
- 19-24 July 1998: 3 oral presentations on Namib fog by 2 DRFN staff (Seely & Mtuleni) in Vancouver, Canada

## Appendix 2: Constructing an SFC

The Standard Fog Collector was described by Schemenauer & Cereceda (1994b) and Cereceda *et al.* (1996). It consists of a  $1 \times 1 \text{m}^2$  screen that covers a frame (aluminium, steel, or galvanized iron), which is fixed on 2-m high legs (Fig. A2.1). A gutter or collection trough is fixed below the screen to collect the water and let it run via a hose (through a raingauge, if possible) into a container where it can be measured manually. The top of the gutter or collection trough should be level with the bottom of the screen and should be 2 cm in front of the screen, while projecting 12 cm behind the screen, so that drops that are loosened from the screen by wind are captured. The bottom of the gutter slopes downwards so that the water runs towards one side (where the hose is).

The composition and size of the screen and the height of its base 2m above the ground are the three most important criteria. The mesh that is used is black Rashel shade netting, which is known as Onion Bag Netting in Namibia (Namibian supplier: Southern Cross Services (Pty) Ltd., Alnet, 1 Bohr Str., P.O.Box 3184, Windhoek, Namibia, Tel: 061-234601; Fax: 061-228489; price N\$8.12/m<sup>2</sup>). It should have a 35% shade coefficient and should be mounted in a double-layer over the frame in such a way that the seams run horizontally and the triangular zigzag weaving vertically. Intercepted fog water can trickle down the vertical fibres, meandering its way down the screen. It is very important to use only this type of mesh for the Standard Fog Collector so as to enable comparison elsewhere. Collectors of fog water where the data are not required for comparison can be of any weave (and are then no longer Standard Fog Collectors). In general the commonly available plaid-weave shade netting (with square spaces between the threads) is not very effective, because these spaces hold the water droplets, thereby reducing the effective capture area. Some other types of mesh are available that are more effective than Rashel. Nevertheless, Rashel is the standard that should be used when first testing a site although one can compare various other materials against it.

The screen should face into the wind that brings the fog. If one is not sure of that, an omni-directional SFC can be used at first (Cereceda *et al.*, 1996; see Appendix 3). Alternatively, observations should be made during the hours of greatest fog precipitation, mostly at night. Preferably, the SFC should be mounted near a weather station that records wind direction and speed. In any case, a fixed SFC is still required to enable one to calculate the actual amount of fog water for a big collector (which has a fixed direction).



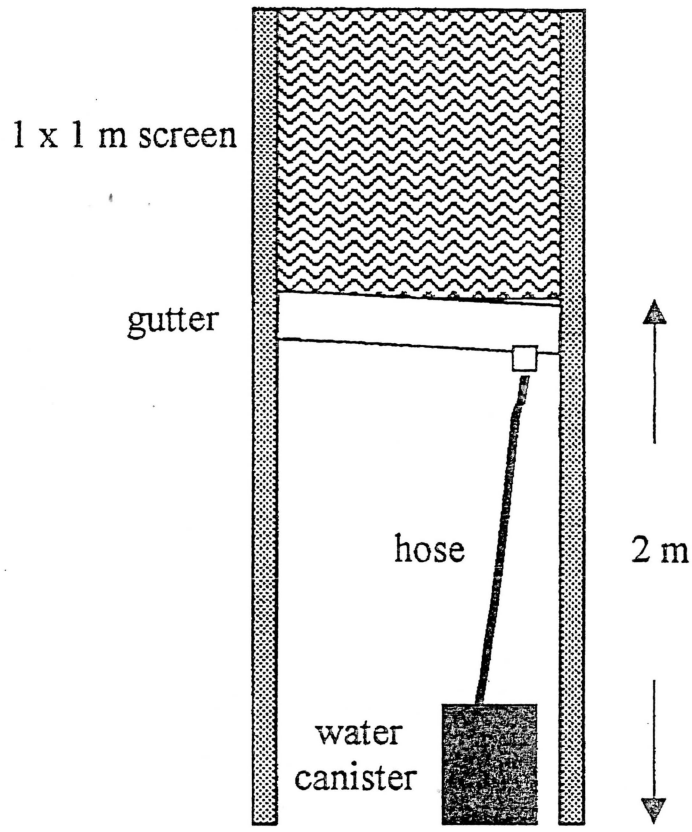

Figure A2.1: Illustration of a Standard Fog Collector.

## Appendix 3: The Bi-Directional Standard Fog Collectors (BSFC)

The Standard Fog Collector (SFC, Schemenauer & Cereceda, 1994b) was designed as a user-friendly instrument to measure fog and make the results directly applicable to the planning of water harvesting schemes. The SFC is a plane that is oriented perpendicularly to the prevailing wind which brings in the fog. It works by the wind pressing the fog through the spaces in the Rashel-type mesh during which some of the water is trapped by the mesh itself and runs downwards into a gutter. Use of the SFC assumes that the direction of the fog-bearing wind can be assessed correctly before SFC deployment.

When fog reaches the SFC at an oblique angle, it may still penetrate the mesh, but the spaces appear to be smaller and the mesh tighter due to the angle of approach, therefore allowing less fog to pass through. Furthermore, the projected area of the screen is smaller than  $1\text{m}^2$ , which is the standard area used for calculations. The plane of the SFC may redirect the fog wind that reaches its surface so that it veers past the screen. For this reason, the SFC is inclined to underestimate the amount of water available at a site, except if the SFC is oriented in the most optimal direction (i.e. directly perpendicular to the prevailing fog wind direction). For this reason the SFC is ill suited to study fog wind directions, because it would underestimate fog coming from certain directions. This cannot easily be compensated for because of the complex interaction of the SFC oriented obliquely to the fog.

Ground winds that cross the vast plains and the isolated inselbergs of the Central Namib are complex and their exact direction is difficult to determine except by measurement. A direction-neutral collector is required to measure the quantity of fog and to determine the best direction. The cylinder-type small collector that has been used for many years is precisely such an instrument. However, its mesh is quite different and not comparable to the Rashel mesh.

Cereceda *et al.* (1996) previously suggested the use of the omni-directional SFC (OFC) to overcome such a problem. It would have the advantage that it should capture fog equally efficiently from all directions. Data from attached anemometers and wind direction sensors would provide information on the fog-bearing wind. The OFC could be used in any terrain, and would provide objective information.

The OFC is constructed as follows. A  $1\text{m}^2$  standard fog screen is mounted onto a pipe that crosses the centre back of the screen. This pipe slips over a round metal rod and is fitted to swivel easily around its axis by resting the closed top of the pipe on a pointed tip of the rod, or by using ball-bearings (the latter are more susceptible to dust). A wind vane is fitted behind the screen in such a way that it turns the screen into the direction from which the wind is blowing. A fixed funnel collects the water from a swivelling hose. Like the SFC, the base of the OFC should be elevated to a height of 2m above the

ground, with its top reaching to 3m. The weather instruments should be 0.5m above these (to avoid interference with the structure).

The OFC may not be suitable for the stormy and dusty Namibian conditions. Its major weaknesses are its fragility in strong Berg winds and the vulnerability of its bearings to dust in sand storms. Its construction is also much more sophisticated and expensive than an SFC. Furthermore, the OFC will not estimate the actual amount that a fixed SFC will yield if oriented in the optimal direction, because the OFC will always have maximum yield in all directions.

We therefore suggest an alternative method of determining the water yield from the optimal direction. This is based on our calculations of the changing efficiency of capturing fog, as the fog intercepts the SFC at different angles. This relationship is expressed by the equation:

$$\text{Proportion of fog collected} = (\text{abs}(\cos(\alpha+\delta))+k)/(1+k)$$

where  $\alpha$ =direction of fog;  $\delta$ =orientation of screen;  $k$ =constant=0.67 (derived empirically)

When the fog intercepts the screen at an oblique angle ( $>45^\circ$ ) the yield declines until the proportion of fog collected drops to 0.4 when the wind direction is parallel to the SFC. This decline is based on measurements of fog collection by two perpendicular screens near Henties Bay during August 1997 (in collaboration with Dr. Kurt Loris). The results indicate that the SFC underestimates the quantity of fog that crosses the screen at a very oblique angle. It may collect only 40% of the amount that it would have collected if it faced directly into the fog (Fig. A3.1). This means that some of the results that are given in the current report could have been twice as high if the SFCs had been oriented NNE instead of NW.

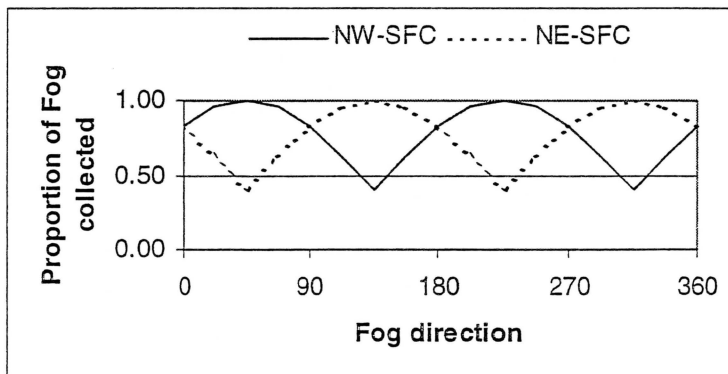
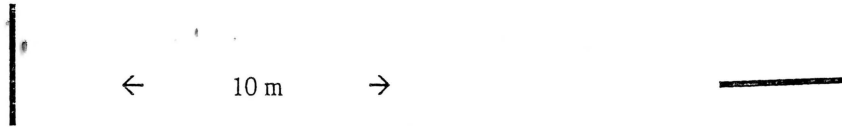

Figure A3.1: Proportion of fog from various directions collected by two SFCs oriented NW and NE.

We suggest that a Bi-Directional SFC (BSFC) comprising two adjacent SFCs (10 m apart) oriented at right angles to each other, compensate for the drop of the yield of oblique fog (Fig.A3.1). Fog arriving at  $45^\circ$  to both screens gives a collection efficiency of 0.82, equal for both SFCs. At different angles, the SFC with the greater yield has an efficiency of  $>0.82$  to 1.0 and should be used to calculate the fog yield. In other words, we suggest that a pair of SFCs, oriented perpendicularly, 10 m apart directly in line with each other (Fig. A3.2) be used to calculate the yield of fog at weather stations. The actual yield for the optimal direction that is determined from this pair can be calculated accordingly.



*Figure A3.2: Relative positioning of the Bi-directional SFC*

After the BSFC has been used to examine a site, the results could be used to extrapolate directly for the design of a fog-water supply scheme. An SFC should be used if the distribution of the fog directions is not unimodal.

The BSFC would be a simple and cheap method of improving the optimal planning of a fog-water harvesting scheme. Orienting an entire water-collector battery in a sub-optimal direction would involve much unnecessary expense and labour and could do the cause of this new technology some harm if a good potential water source is misjudged as being a poor source. It would also avoid unnecessary disappointment for users of a constructed fog-collecting scheme who are living on the edge of water scarcity and need every available drop of water.

We therefore propose to use the BSFC at potential fog-collecting sites in Namibia.

## Appendix 4: Costs of Elements of Various Types of Water Supply

\* = self = community does this itself; cash flow not necessarily involved.

### Water Management Costs

(for all supply types, following Greiner, 1997)

		<b>520 h* + N\$45 367</b>
<b>1)</b>	<b>Piping &amp; Treatment</b>	<b>N\$17 250</b>
a)	pipes & intermediate tanks	N\$1 012+ 2431+12298 15 741
b)	gauge	509
c)	labour	200 h @ N\$5/hr 1 000
<b>2)</b>	<b>Water Storage</b>	<b>N\$19 268</b>
a)	50 m <sup>3</sup> reservoir	N\$15 195 + 3 073 18 268
b)	labour	200 h @N\$5/hr 1 000
<b>3)</b>	<b>Water Supply</b>	<b>N\$8 849</b>
a)	pipes, taps & accessories:	N\$4 169+1 012 5 181
b)	trough	N\$2 049+5 110 7 159
c)	gauge	509
d)	labour	200 h @ N\$5/hr 1 000
<b>4)</b>	<b>Annual maintenance</b>	<b>52 h* + N\$6 162</b>
a)	management	1h/week = 52 h/yr self
b)	material	10% of total installation & management cost 4 537
c)	transport & labour	1 x (500 km/1-day trip + N\$250 per day) 1 625

### Water Source Costs (Greiner, 1997)

#### A: Installation & Maintenance

<b>1)</b>	<b>25 Fog Collectors: 10 years</b>	<b>13400 h* + N\$ 132 000</b>
a)	Installation	<b>3000 h* + N\$ 66 000</b>
	i) 25 FCUs	@ N\$2640 66 000
	ii) labour:	120 h/FCU x25 = 3000 h self
b)	Annual operation & maintenance x 10 yrs	<b>1040 h* + N\$ 6 600</b>
	i) operation	0
	ii) material	10% of installation 6 600
	iii) transport & labour	20 h/week = 1040 h self

2)	<b>Diesel (30m borehole): 10 yrs</b>		<b>3650 h* + N\$174 336</b>
a)	Installation		<b>N\$27 386</b>
	i) borehole	N\$2711+949	3 660
	ii) engine	N\$3 300+3 889+2 442+4 455+1 417+3 207	18 710
	iii) labour		5 016
b)	Annual operation & maintenance		<b>365 h* + N\$ 14 695</b>
	i) operation, diesel	N\$5/day	1 825
	ii) management	1 h/day = 365h	self
	iii) material		6 370
	iv) transport & labour	4 x (500 km/1-day trip + N\$250 per day)	6 500
3)	<b>Windmill (30m borehole): 10 yrs</b>		<b>3650 h* + N\$116 367</b>
a)	Installation		<b>N\$24 137</b>
	i) borehole	N\$ 2706+953	3 659
	ii) windmill	N\$ 11792+636+3655	5 463
	iii) labour		15 015
b)	Annual operation & maintenance		<b>365 h* + N\$ 9 223</b>
	i) operation		0
	ii) management	1 h/day = 365h	self
	iii) material		2 723
	iv) transport & labour	4 x (500 km/1-day trip + N\$250 per day)	6 500
4)	<b>Hand-dug well (10m): 10 yrs</b>		<b>31 220 h* + N\$ 11 200</b>
a)	Installation		<b>100 h* + N\$ 1 200</b>
	i) well	(100 poles valued @ N\$10 each)	1 000
	ii) buckets/ropes/pulleys		200
	iii) labour: (100 h)		self
b)	Annual operation & maintenance		<b>3 120 h + N\$ 1 000</b>
	i) operation		0
	ii) replacement		1 000
	iii) repair 100 h		self
	iv) fetch water	8 h/day x 365 = 2920 h	self

## Appendix 5: Sites where SFCs were deployed

Place	Site	GPS-Co-ordinates	Altitude (m amsl)	Distance from Coast (km)	Period with SFC
<b>Gobabeb</b>	SFC Weather station	S 23°33'37,7" E 15°02'29,4"	406	56	Jul 96-
	SFC Caravan Park				
	SFC Dunes (5 km S)				
	SFC Quartz Hill (2 km N)				
<b>Klipneus</b>	Settlement	S 23° 23'55,9" E 14°54'07,0"	352	46	
	Reservoir (10 m <sup>3</sup> )	S 23°23'59,8" E 14°54'07,4"	357		
	SFC Lower Klipneus (manual)	S 23°23'42,3" E 14°53'47,8"	360		Oct 96 – Dec97
	SFC Top (logger)	S 23°22'11,5" E 14°54'36,7"	417		Oct 96 -
	SFC North (logger)	S 23°22'32,2" E 14°55'07,7"	399		Apr 98 -
	SFC Nose (manual)	S 23°23'22,5" E 14°54'32,7"	384		Apr 98 -

<b>Swartbank</b>	Settlement	S 23°20'16,3" E 14°51'35,0"	308	37	
	Reservoir (20 m <sup>3</sup> )	S 23°20'11,1" E 14°51'09,0"	316		
	SFC S Slope (logger)	S 23°19'47,0" 14°48'40,8"	342		Oct 96 -
	SFC S Peak (manual)	S 23°33'40,9" E 15°02'27,3"	439		Oct 96 –Dec97
	SFC Top Ridge (manual)				Oct 96 –Dec97
	SFC Plain (logger)	S 23°22'11,4" E 14°54'36,6"	390		Apr 98 -
<b>Rooibank</b>		S 23°11' E 14°38'	219	18	



## Appendix 6: Data sheets on Three Topnaar Settlements

Swartbank			
	Household 1	Household 2	Household 3
<b>No. permanent residents</b>	3 adults / 2 children	5 adults / 3 children	2 adults
<b>No. school children</b>	1 child	2 children	2 children
<b>No. commuters to Walvis</b>	0	6 adults / 6 children	7 adults / 3 children
<b>No. water consumers:</b>			
<b>In a normal week</b>	5	8	2
<b>At weekends</b>	5	8 or 9	2 up to 10
<b>During holidays</b>	6	22	14
<b>Water used:</b>			
<b>Cooking per day</b>	22L	100l (90l for people, 10l for dogs, cats, chickens)	8l (5l for people, 3l for dogs)
<b>Bathing per day</b>	25l (5l per person)	320l (40l per person)	16l (8l per person)
<b>Washing per week / month</b>	50l (once a week)	150l (40l twice a week + 10l seven times a week for children's clothes)	~ once a month (washes whenever in Walvis Bay)
<b>4. Reuse of water</b>	No reuse	For watering plants	No reuse
<b>5.a) No. livestock:</b>			
<b>Goats</b>	9	61	26
<b>Donkeys</b>	4	27	13
<b>Cattle</b>	10	14	2

<b>Other animals</b>	17 chicken / 1 dog	15 chickens / 3 dogs / 1 cat	2 dogs
<b>b) Sale of livestock</b>	in average per year: about 1-2 cattle 1-2 goats		only if necessary (financial support)
<b>6. a) Livestock water provision</b> <b>b) Livestock water consumption:*</b> <b>Goats</b> <b>Donkeys</b> <b>Cattle</b>	Animals watered until they drink no more  See Klipneus		
<b>7. Gardens</b>	No garden	No garden, only a few herbs for tea	No garden

<b>8.a) Water sources;</b> <b>Reservoir (m<sup>3</sup>)* / bore hole</b>  <b>Hand-dug well</b> <b>Other source</b>  <b>b) Maintenance</b>  <b>c) Preferred water source</b>	<p>3 reservoirs: 2 for people (approx. 2x 4m<sup>3</sup>) / 1 for livestock (approx. 12m<sup>3</sup>) – the reservoirs are not intact and at present they are empty.</p> <p>3 hand-dug wells: 2 for people / 1 for livestock</p> <p>for people: Utuseb school –for example: household 3 collects 8x 25l water once a week; household 1 collects 2x25l four times a week</p> <p>for livestock: shallow pan nearby; this fills up when the river comes down and supplies livestock with water until it dries up.</p> <p>J. Animab maintains reservoirs whenever is here; local people, men and women maintain hand dug wells.</p> <p>They prefer the water from the dug well because it is not as salty as the water in the reservoirs.</p>
---	---

<b>d) Regularity of supply</b>	Varies with well and season: the water level in the well used by people drops in the dry-season so they have to dig deeper; the supply in the well used by livestock is continuous throughout the year.
<b>e) Seasonal water consumption</b>	Water consumption's higher in the summer
<b>Collection of water:</b> <b>Who collects?</b> <b>Containers used?</b> <b>How often?</b> <b>Distance from source</b>	Everybody collects water, as they need it. 5l-n 25l 2 – 3x day per person, sometimes once a day (donkey cart) + weekly trips to Ituseb (see question 8a.) 150 – 500m from dug wells – varies with each household + 20 km to Ituseb
<b>10. Knowledge of fog project</b>	One person had a good understanding of the project having spoken to Snake shortly after the installation of the new fog screen at swartbank. However, most people don't know much about this project, but they seem to be positive about it; water is very important for domestic + livestock use – if fog could provide them with more water they would welcome it and be willing to help.
<b>11. Effect of increased water supply:</b> <b>On number of livestock</b> <b>On number / size of gardens</b>	They would increase the number of livestock They would have / increase the size of gardens
<b>12. Interest in learning more about water situation in relation to fog</b>	They are interested in learning more – preferably from Alois and Snake

<b>Klipneus</b>	
	<b>Household 1 + 2</b>
<b>No. permanent residents</b>	
No. school children	3 adults / 3 children
<b>No. commuters to Walvis Bay</b>	1 child
	6 adults
<b>No. Water consumers:</b>	
<b>In a normal week</b>	6
<b>At weekends</b>	6
<b>During holiday</b>	13
<b>Water used:</b>	
<b>Cooking per day</b>	25l
<b>Bathing per day</b>	48l (8l per person)
<b>Washing per week / month</b>	220l (40l twice a week +20l seven times a week for children's clothes)
<b>4. Reuse of water</b>	No reuse (except for watering one tomato plant)
<b>5.a) No. livestock:</b>	
<b>Goats</b>	50
<b>Donkeys</b>	20
<b>Cattle</b>	16
<b>Other animals</b>	27 chickens / 7 dogs
b) Sale of livestock	only if necessary ( financial support) – no sale since last year

<p><b>6. a) Livestock water provision</b></p> <p><b>b) Livestock water consumption:*</b></p> <p><b>Goats</b></p> <p><b>Donkeys</b></p> <p><b>Cattle</b></p>	<p>1-2l twice a day → result of a experiment</p> <p>16-18l once a day → result of a experiment</p> <p>40-50l once a day → result of literature</p>
<p><b>7. Gardens</b></p>	<p>No garden, only one tomato plant</p>
<p><b>8. a) Water sources:</b></p> <p><b>Reservoir (m<sup>3</sup>)* / bore hole</b></p>	<p>2 reservoirs: 2 for people ( approx. 2x 4m<sup>3</sup>)</p>
<p><b>Hand – dug well</b></p> <p><b>Other source</b></p> <p>b) Maintenance</p> <p><b>c) Preferred water source</b></p> <p><b>d) Regularity of supply</b></p> <p><b>e) Seasonal water consumption</b></p>	<p>None at present – in the past they had one, but when the river came down it became blocked; they are currently considering digging it again because the water quality is better</p> <p><b>Wind pump</b></p> <p>Maintenance by residents not possible</p> <p>They would prefer the water from the dug well because it is not as salty / brackish as the water in the reservoirs</p> <p>Varies with season: the water level is deeper in the summer</p> <p>Water consumption is higher in the summer</p>
<p><b>9. Collection of water:</b></p> <p><b>Who collects?</b></p> <p><b>Containers used?</b></p>	<p>Everybody collects water as they need it</p> <p>5l– 20l</p>

<b>How often?</b>	1 – 2 times a day per person
<b>Distance from source*</b>	150m
<b>10. Knowledge of fog project</b>	Alois has a good understanding of the project, but he would be happy to learn more about water situation in relation to fog. Most people don't know much about this project, but if they could use the fog water they would appreciate it more.
<b>Effect of increased water supply</b> <b>On number of livestock</b> <b>On number / size of gardens</b>	They wouldn't increase the number of livestock They wouldn't have / increase the size of gardens Enough water is available now so increased water supply would have no effect
<b>12. Interest in learning more about water situation in relation to fog</b>	They are interested and would like to have more information – preferably from Alois and Snake

<b>Soutriver</b>					
Geography	Location: 23° 32'S; 15° 02'E / Distance from coast: 53km ? Distance up river 84km / Village households: ? / Inhabitants: ? /Existing Reservoir: ± 57m <sup>3</sup> / Caretaker: Daniel SFC-C (Sriv) SFC Distance from reservoir ± 200m N / SFC Position: 50m S of N end ridge on S bank of wash / SFC Direction across: 225° / N-S Direction of ridge: 278° / Length of potential Fcu line: 220m / Altitudes: 387m; bottom of ridge: 376m; village: ? / Indirect Fog evidence: none				
	Household 1	Household 2	Household 3	Household 4	Household 5
Question					
<b>No. permanent residents</b>	2 adults / 4	1 adult	2 adults	3 adults	2 adults
<b>No. school children</b>	children	0	2 children	1 child	2 children
<b>No. commuters to Walvis</b>	2 children 1 adult / 1 child	1 adult	7 children	1 child	2 adults / a few children
<b>No water consumers:</b>					
<b>In a normal week</b>	6	1	2	3	2
<b>At weekends</b>	6	1 or 2	2 up to 9	3 or 4	2
<b>During holidays</b>	10	2	11	4	6 up to 10
<b>Water used:</b>					
<b>Cooking per day</b>	25 L	5 L	5l	10 L	10 L
<b>Bathing per day</b>	40l(15lfor 2 adults, 25lfor 4 children) 90l(45ltwice a	no answer	10l(5lper person)	no answer	no answer

Washing per week / month	week)	once a month	90l(45ltwice a week)	once a week	80l(once an month
<b>4. Reuse of water</b>	For watering plants	No reuse	No reuse	For watering plants	No reuse
<b>5.a) No. livestock:</b>					
Goats	20	3	8	7	
Donkeys	16	0	0	a few	
Cattle	0	0	0	0	
Other animals	3 chickens / 2 dogs	5 sheep / 1 chicken	4 chicken / 3 dogs	4 chickens / 2 dogs	
<b>b) Sale of livestock</b>	only if necessary (financial support)	only if necessary (financial support)	only if necessary (financial support)	no sale	
<b>6.a) Livestock water provision</b>	Animals watered until they drink no more				
<b>b)Livestock water consumption:*</b>	See Klipneus				
Goats					
Donkeys					
Cattle					
<b>7. Gardens</b>	A small one in the river bed	No garden	A small one in the river bed	No garden, but a few shrubs	No garden



<p><b>8. a) Water sources:</b></p> <p><b>Reservoir (m<sup>3</sup>)* / bore hole</b></p> <p><b>Hand-dug well</b></p> <p><b>Other source</b></p> <p><b>b.) Maintenance</b></p> <p><b>c.) Preferred water source</b></p> <p><b>d.) Regularity of supply</b></p> <p><b>e.) Seasonal water consumption</b></p>	<p>2 reservoirs: 1 for people (approx. 3.5m<sup>3</sup>) / 1 for livestock (approx. 53m<sup>3</sup>)</p> <p>none at present – in the past they had one, but when the river came down it became blocked they also had a wind pump, but after the bore hole / reservoir was established, it was removed</p> <p>maintenance by residents not possible</p> <p>no preference – the water quality is the same</p> <p>continuous throughout the year</p> <p>water consumption is higher in the summer</p>
<p><b>Collection of water:</b></p> <p><b>Who collects?</b></p> <p><b>Containers used?</b></p> <p><b>How often?</b></p> <p><b>Distance from source*</b></p>	<p>Everybody collects water as they need it</p> <p>5 – 25 L</p> <p>2 – 3 times a day per person</p> <p>100m – 400m; varies with each household</p>
<p><b>10. Knowledge of fog project</b></p>	<p>They don't know much about this project, but they were told that in times of water shortage it may provide them with water. If the project is implemented, they will be willing to help.</p>
<p><b>11. effect of increased water supply:</b></p> <p><b>On number of livestock</b></p>	<p>They would increase the number of livestock</p> <p>They would have / increase the size of gardens</p>

<b>On number / size of gardens</b>	
<b>Interest in learning more about water situation in relation to fog</b>	They are interested and would like to have more information – preferably from Alois, Daniel or Snake